

# MASON INDUSTRIES, Inc.

Manufacturers of Vibration Control Products  
 350 Rabro Drive 2101 W. Crescent Ave., Suite D  
 Hauppauge, NY 11788 Anaheim, CA 92801  
 631/348-0282 714/535-2727  
 FAX 631/348-0279 FAX 714/535-5738  
 Info@Mason-Ind.com Info@MasonAnaheim.com  
 www.Mason-Ind.com

JOB NAME \_\_\_\_\_  
 CUSTOMER \_\_\_\_\_  
 CUSTOMER P.O. \_\_\_\_\_  
 MASON M.I. \_\_\_\_\_  
 DWG. NO. \_\_\_\_\_

**30**  
 1" (25mm)  
 Deflection  
 X, A, B, C, D & F  
 Spring Series  
 Hangers

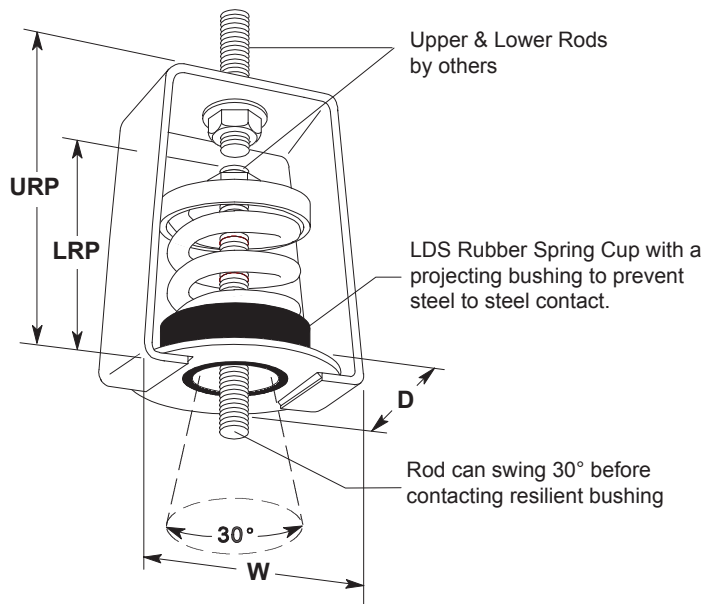

LRP - Lower Rod Penetration  
 MRD - Maximum Rod Diameter

### TYPE 30 DIMENSIONS

Size Range	D		H		W		LRP		MRD
	(in)	(mm)	(in)	(mm)	(in)	(mm)	(in)	(mm)	(in)
30-X-23-210	2 1/2	64	4 1/4	108	2 7/8	73	3 1/2	89	3/8 10
30-A-12-25	2 3/4	70	5 3/4	146	3 1/4	83	3 1/2	89	5/8 16
30-A-41-95	2 3/4	70	5 3/4	146	3 1/4	83	4	102	5/8 16
30-B-138-540	4	102	7 1/4	184	4 3/4	121	4 1/4	108	5/8 16
30-C-630-1265	4	102	8 3/4	222	5 1/4	132	5	127	3/4 19
30-D-1575-2150	4 3/4	121	12 1/2	318	5 3/4	146	7	178	7/8 22
30-F-2760	6	152	12	305	6 1/4	159	7	178	7/8 22

### TYPE 30 RATINGS

Size	Rated Capacity		Rated Defl.		Spring Constant		Spring Color
	(lbs)	(kg)	(in)	(mm)	(lbs/in)	(kg/mm)	
30-X-12	12	5	1.25	32	10	0.18	Orange
30-X-23	23	10	1.30	33	18	0.30	Brown
30-X-33	33	15	1.10	28	30	0.54	Copper
30-X-54	54	24	1.20	30	45	0.80	White
30-X-76	76	34	1.02	25	73	1.36	Black
30-X-113	113	51	1.00	25	113	2.04	Brass
30-X-130	130	59	1.00	25	130	2.36	Purple
30-X-175	175	79	1.00	25	175	3.16	Silver
30-X-210	210	95	1.00	25	210	3.80	Blue
30-A-12	12	5	1.00	25	12	0.20	Copper
30-A-18	18	8	1.00	25	18	0.32	Gray
30-A-25	25	11	1.00	25	25	0.44	Orange
30-A-41	41	19	1.18	30	35	0.63	Pink
30-A-56	56	25	1.14	30	49	0.83	Black
30-A-73	73	33	1.06	27	69	1.22	Tan
30-A-95	95	43	1.01	25	94	1.65	Green
30-B-138	138	63	1.32	34	105	1.85	White
30-B-222	222	101	1.16	29	191	3.48	Blue
30-B-278	278	126	1.09	28	255	4.50	Purple
30-B-336	336	152	1.00	25	336	6.08	Silver
30-B-410	410	186	1.07	27	385	6.89	Black
30-B-540	540	245	1.00	25	540	9.80	Yellow
30-C-630	630	286	1.13	29	558	9.86	Gray
30-C-800	800	363	1.00	25	800	14.52	Orange
30-C-1010	1010	458	1.10	28	920	16.36	Green
30-C-1265	1265	574	1.00	25	1265	22.96	Red
30-D-1575	1575	714	1.23	31	1280	23.03	Pink
30-D-2150	2150	975	1.03	26	2095	37.50	Purple
30-F-2760	2760	1252	1.00	25	2760	50.08	Silver

All springs have additional travel to solid equal to 50% of Rated Deflection.

LDS stands for Low Dynamic Stiffness Bridge Bearing Natural Rubber to minimize noise and vibration transmission.

### PLAN VIEW OF HANGER LOCATIONS

TAG: \_\_\_\_\_

UNIT: \_\_\_\_\_



### SPECIFIED DEFLECTION

1 :	6 :
2 :	7 :
3 :	8 :
4 :	9 :
5 :	10 :

Sets Required: