



MASON INDUSTRIES, Inc.

Manufacturers of Vibration Control Products

350 Rabro Drive
Hauppauge, NY 11788
631/348-0282
FAX 631/348-0279
Info@Mason-Ind.com
www.Mason-Ind.com

2101 W. Crescent Ave., Suite D
Anaheim, CA 92801
714/535-2727
FAX 714/535-5738
Info@MasonAnaheim.com
www.MasonAnaheim.com

ALL DIRECTIONAL ANCHORS and VERTICAL SLIDING GUIDES for RISERS with STRAIGHT PIPE, OFFSETS or EXPANSION JOINTS

ADA & VSG

DATA SHEET DS-510-3

ADA

All Directional Anchors

Change designation to ADAH when base plate with bolt holes is required.

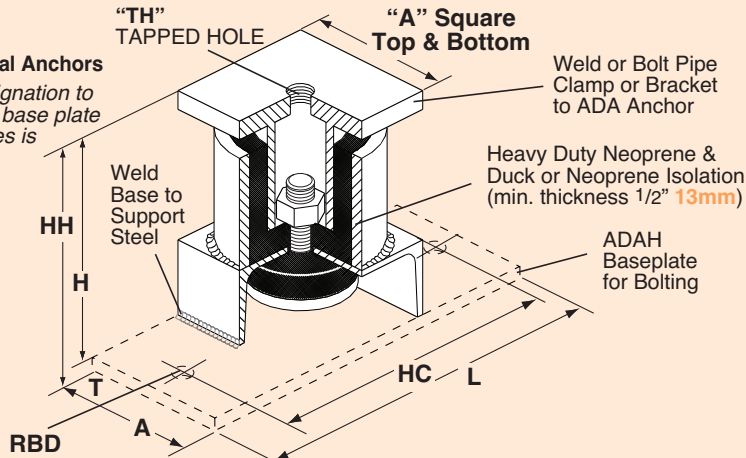

TYPE ADA and ADAH RATINGS

Type	Size	Anchoring Capacity per Pair		Rated Defl	
		(lbs)	(kg)	(in)	(mm)
ADA-	75	1,000	453	0.1	2.5
	200	6,000	2722	0.1	2.5
	350	24,000	10886	0.1	2.5
ADAH-	600	60,000	27216	0.1	2.5
	800	100,000	45359	0.1	2.5

Each pair of ADA(H) all directional anchors provides high frequency noise and vibration isolation for those locations where movement must be controlled.

When the anchors are attached to piping as shown in the illustrations below, all expansion will be directed from this point.

Anchors are always used in pairs.

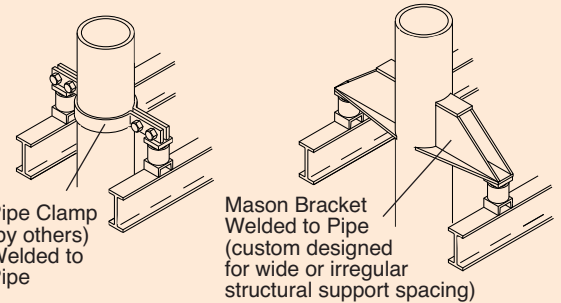

*Size 350 - Top is 5" 127mm x 5" 127mm, Bottom is 6" 152mm x 6" 152mm.

TYPE ADA and ADAH DIMENSIONS (inches and mm)

RBD-Required Bolt Dia. for Max. Loading

Type	Size	A	H	L	T	HC	HH	RBD	TH
ADA-	75	3 76	4 1/2 114	6 152	1/4 6	5 127	4 3/4 121	3/8 10	1 1/2-13UNC
	200	4 102	7 178	11 279	3/8 10	8 1/2 216	7 3/8 187	5/8 16	5/8-11UNC
	350	* 184	7 1/4 184	12 305	1/2 13	9 1/2 241	7 3/4 197	3/4 19	None
ADAH-	600	9 229	11 279	14 1/2 368	3/4 19	12 305	11 3/4 298	1 1/4 32	None
	800	11 279	13 1/2 343	17 1/2 445	1 25	14 1/2 368	14 1/2 368	1 1/2 38	None

VSG

Vertical Sliding Guide

Change designation to VSGH when base plate with bolt holes

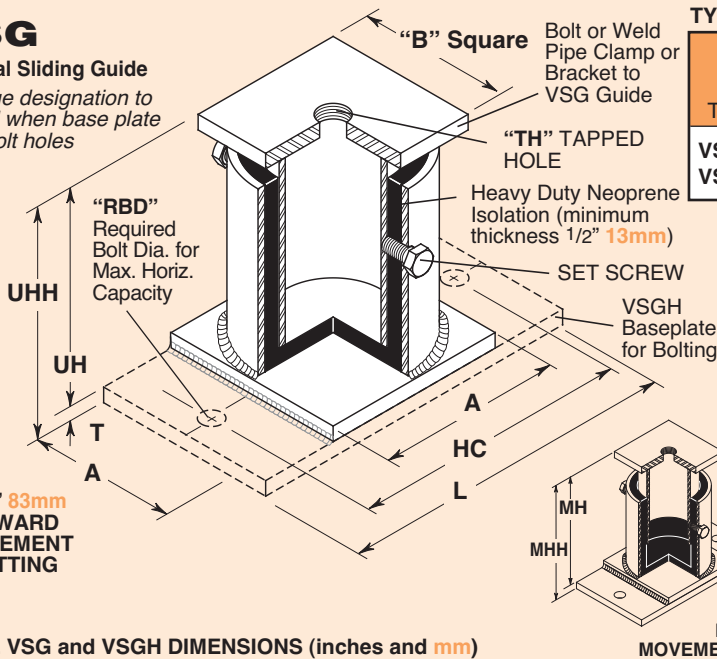

TYPE VSG and VSGH RATINGS

Type	Size	Horizontal Capacity per Pair		Possible Horizontal Deflection		For use with Pipe Sizes
		(lbs)	(kg)	(in)	(mm)	(in) (mm)
VSG- VSGH-	75	1,000	453	0.1	2.5	thru 5 125
	200	8,000	3629	0.1	2.5	6 150 thru 12 300
	350	11,300	5126	0.1	2.5	14 350 thru 24 600

Each pair of VSG guides provides high frequency noise and vibration isolation for those locations where movement must be guided in the axial direction.

Standard VSG Guides can be set to accommodate:

- 0 Upward Movement and 3 1/4" 83mm Downward Movement.
- 3 1/4" 83mm Upward Movement and 0 Downward Movement.
- 15/8" 41mm Upward or Downward Movement.
- Special settings as required and certified.

Guides are always used in pairs.

When pairs of VSG Guides are used as shown in the illustrations below right, radial motion is controlled while axial motion is guided.

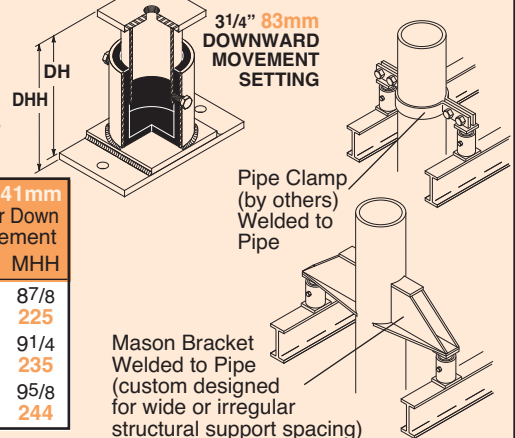

TYPE VSG and VSGH DIMENSIONS (inches and mm)

Type	Size	A	B	L	T	HC	RBD	TH	3 1/4" 83mm Downward Movement		3 1/4" 83mm Upward Movement		15/8" 41mm Up or Down Movement	
									DH	DHH	UH	UHH	MH	MHH
VSG-	75	3	3	6 1/4	1/4	5	3/8	1 1/2-13UNC	10 1/4	10 1/2	7	7 1/4	85/8	87/8
	200	6	76	159	6	127	10		260	267	178	184	219	225
		4 1/2	114	248	6	203	16		101 1/2	107 8	71 4	75 8	87 8	91 4
VSGH-	350	6	5	11	1/2	9	3/4	1-8UNC	103 4	111 4	71 2	8	91 8	95 8
		152	127	280	13	229	19		273	286	191	203	232	244

Pipe Size (in) (mm)	RECOMMENDED ANCHOR SIZE SELECTIONS				SIZE SELECTIONS & MAXIMUM RECOMMENDED VERTICAL GUIDE SPACING TO PREVENT PIPE BUCKLING							
	Pair of Anchors Used to Resist Expansion Joint Thrust Illustration 1		A Pairs of Anchors Used to Resist Offset Thrust Illustration 1		GUIDE SIZES	Straight Solid Riser	Offset Solid Riser	Risers Having Expansion Joints				
								Theoretical Non-Supportive Directional Guides Illustration 2	One Guide Each End and Maximum Distance Between Guides D	One Anchor Each End and Maximum Distance Between Guides D	Stainless Steel	
	Operating Pressures	Up to 150 psi 10kg/cm ² Size	300 psi 20kg/cm ² Size	Offset (ft) (m)	Size	Size	Distance Joint to First Guide D				Distance First to Second Guide D	Distance Joint to Second Guide Second not Required D
								150 psi 10kg/cm ²	300 psi 20kg/cm ²			
1	ADA-75	ADA-75	7.4	ADA-75	VSG-75	40	24	8"	2'-0"	8"	12	12
25	ADA-75	ADA-75	2.26	ADA-75	VSG-75	12	7	.20	0.61	0.20	3.66	3.66
11/4	ADA-75	ADA-75	8.2	ADA-75	VSG-75	40	24	8"	2'-0"	8"	12	12
35	ADA-75	ADA-75	2.5	ADA-75	VSG-75	12	7	.20	0.61	0.20	3.66	3.66
11/2	ADA-75	ADA-75	9.0	ADA-75	VSG-75	40	24	10"	3'-0"	10"	12	12
40	ADA-75	ADA-75	2.7	ADA-75	VSG-75	12	7	.25	0.91	0.25	3.66	3.66
2	ADA-75	ADA-75	9.8	ADA-75	VSG-75	40	24	10"	3'-0"	10"	12	12
50	ADA-75	ADA-75	3.0	ADA-75	VSG-75	12	7	.25	0.91	0.25	3.66	3.66
21/2	ADA-75	ADA-200	11.0	ADA-75	VSG-75	40	30	12"	3'-6"	12"	12	12
65	ADA-75	ADA-200	3.4	ADA-75	VSG-75	12	9	.31	1.07	0.31	3.66	3.66
3	ADA-75	ADA-200	12.3	ADA-75	VSG-75	40	36	12"	3'-6"	12"	17	14
80	ADA-75	ADA-200	3.7	ADA-75	VSG-75	12	11	.31	1.07	0.31	5.18	4.27
4	ADA-75	ADA-200	13.9	ADA-75	VSG-75	40	36	1'-4"	4'-8"	1'-4"	25	19
100	ADA-75	ADA-200	4.2	ADA-75	VSG-75	12	11	.41	1.42	0.41	7.62	5.80
5	ADA-75	ADA-200	15.0	ADA-75	VSG-75	50	36	2'-0"	7'-0"	2'-0"	30	23
125	ADA-75	ADA-200	4.6	ADA-75	VSG-75	15	11	.61	2.134	0.61	9.14	7.01
6	ADA-200	ADA-350	16.8	ADA-200	VSG-200	50	36	2'-0"	7'-0"	2'-0"	37	27
150	ADA-200	ADA-350	5.1	ADA-200	VSG-200	15	11	.61	2.134	0.61	11.28	8.23
8	ADA-200	ADA-350	18.8	ADA-200	VSG-200	50	50	2'-6"	9'-4"	2'-6"	45	33
200	ADA-200	ADA-350	5.7	ADA-200	VSG-200	15	15	.76	2.85	0.76	13.72	10.06
10	ADA-200	ADA-350	21.3	ADA-200	VSG-200	60	60	3'-4"	11'-8"	3'-4"	58	42
250	ADA-200	ADA-350	6.5	ADA-200	VSG-200	18	18	1.0	3.56	1.07	17.68	12.80
12	ADA-350	ADA-600	23.0	ADA-350	VSG-200	72	72	4'-0"	14'-0"	4'-0"	60	48
300	ADA-350	ADA-600	7.0	ADA-350	VSG-200	22	22	4.0	4.27	0.41	18.29	14.63
14	ADA-350	ADA-600	24.0	ADA-350	VSG-200	85	85	4'-8"	16'-4"	4'-8"	71	51
350	ADA-350	ADA-600	7.3	ADA-350	VSG-200	26	26	1.4	4.98	1.43	21.64	15.55
16	ADA-350	ADA-600	25.8	ADA-350	VSG-200	85	85	5'-4"	18'-8"	5'-4"	78	56
400	ADA-350	ADA-600	7.9	ADA-350	VSG-200	26	26	1.6	5.69	1.63	23.75	17.07
18	ADA-600	ADA-800	27.5	ADA-350	VSG-200	85	85	6'-0"	21'-0"	6'-0"	85	61
450	ADA-600	ADA-800	8.4	ADA-350	VSG-200	26	26	1.8	6.40	1.83	25.91	18.95
20	ADA-600	ADA-800	29.0	ADA-350	VSG-200	120	120	6'-8"	23'-4"	6'-8"	91	65
500	ADA-600	ADA-800	8.8	ADA-350	VSG-200	37	37	2.0	7.11	2.03	27.74	19.81
24	ADA-800	Special Designs as Required	—	ADA-600	VSG-350	120	120	8'-0"	28'-0"	8'-0"	103	75
600	ADA-800	Special Designs as Required	—	ADA-600	VSG-350	37	37	2.4	8.53	2.44	31.40	22.86
26	ADA-800	Special Designs as Required	—	ADA-600	VSG-350	120	120	10'-0"	35'-0"	10'-0"	118	85
650	ADA-800	Special Designs as Required	—	ADA-600	Special Designs As Required	37	37	3.0	10.67	3.05	35.97	25.91
28	ADA-800	Special Designs as Required	—	ADA-600	Special Designs As Required	120	120	10'-0"	35'-0"	10'-0"	118	85
700	ADA-800	Special Designs as Required	—	ADA-600	Special Designs As Required	37	37	3.05	10.67	3.05	35.97	25.91
30	ADA-800	Special Designs as Required	—	ADA-600	Special Designs As Required	120	120	10'-0"	35'-0"	10'-0"	118	85
750	ADA-800	Special Designs as Required	—	ADA-600	Special Designs As Required	37	37	3.05	10.67	3.05	35.97	25.91

A Reference forces calculated on standard reference for 1" 25mm movement at pipe stress of 15000 psi 1050 kg/cm².

B If the anchor is next to the joint on one side, no guide is needed on that side.

C Guides beyond the anchor may be spaced as in a straight solid run since there is no thrust force.

Illustration 1

ADA ANCHOR

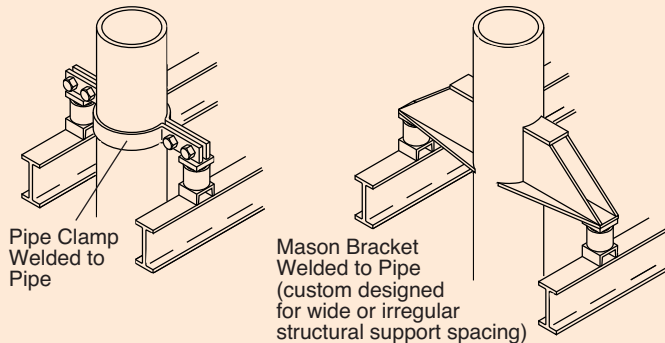
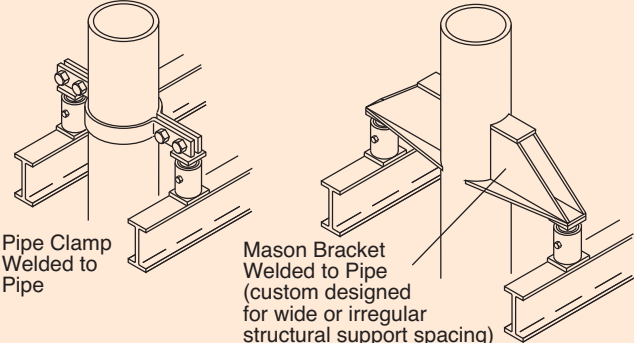

Illustration 2

VSG SLIDING GUIDE



To more clearly define and control riser load shifts caused by pipe expansion and contraction, strategically placed spring supports may be incorporated. See Hanger Bulletin H-610 (page 13) for a detailed description of this method using type SLFH Steel Spring Mounts or type HES Pipe Expansion Hangers.