



MASON INDUSTRIES, Inc.

MERCER RUBBER Co.

350 Rabro Drive, Hauppauge, NY 11788
Mason- 631/348-0282 • Info@Mason-Ind.com
Mercer- 631/582-1524 • Info@Mercer-Rubber.com
FAX 631/348-0279



JOB NAME
CUSTOMER
CUSTOMER P.O.
MASON M.
DWG No.

EW250-SS-NSF

250 psi FULL VACUUM SS BELLOWS EXPANSION JOINT with WELD ENDS

ALL COMPONENTS STAINLESS STEEL

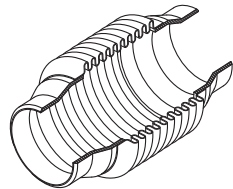
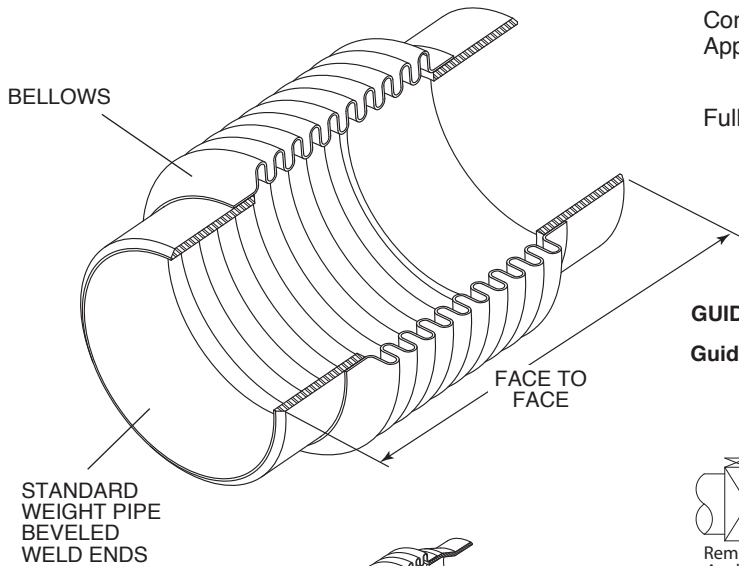

Our 2" - 4" designs use 5" bellows between reducers for greater stability.

Conforms to UL and ANSI/NSF 61 Approved Temperature Range.

Full Vacuum Rating- 30" (762mm) Hg



WATER QUALITY DRINKING WATER SYSTEM COMPONENT ANNEX G of ANSI / NSF 61 (4RV6)

GUIDE SPACING - Referencing Pipe Diameter "D"

Guides and Anchors for Joint located near Anchor

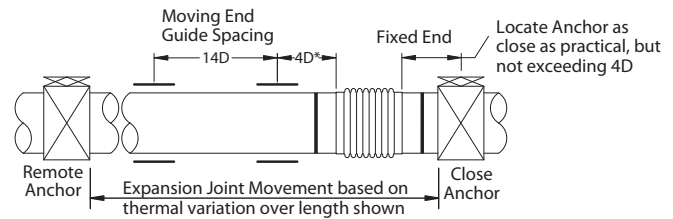

Guides and Anchors for Joint located between Remote Anchors

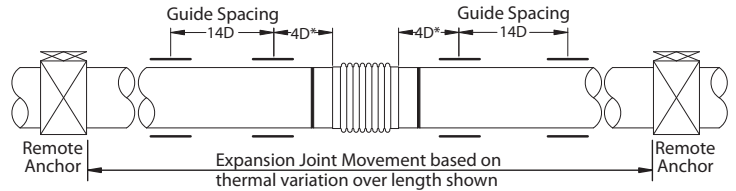

EW250-SS-NSF DIMENSIONS AND PRESSURE RATINGS (American & Metric Units) 2" (50mm) AXIAL MOVEMENT, 1/4" (6mm) LATERAL DEFLECTION

Table with 9 columns: Type & Size, Pipe Size (in/mm), Face to Face (in/mm), Axial Spring Rate (lbs/in/kg/cm), Lateral Spring Rate (lbs/in/kg/cm), Thrust @ 250 psi / 17 kg/cm² (lbs/kg), Rated Pressure @ 70°F / 21°C (psi/kg/cm²), Ship Wt. (lbs/kg). Rows include models EW250-SS-NSF-2 through EW250-SS-NSF-16.

EW may be used for 2" Expansion or 2" Compression from neutral length or any combined 2" from neutral. i.e. (+ 1 1/2, - 1/2) (+ 1, - 1) (+ 1/4, - 1 3/4) etc. Total movement should never exceed 2".

Lower Thrust Forces in proportion at lower pressures, i.e. 100 psi Force = 100/250 x published Thrust. Anchors must resist Thrust Force plus Spring Force. Spring Force is determined by multiplying the joint Spring Rate by its Thermal Movement (in/mm).

EW's installed in piping systems must be anchored on both sides of the joint. EW's installed in unanchored piping must have control rods.

When using EW products in copper or brass water systems, dielectric unions must be used on each end to prevent leakage from galvanic action.

Table with 3 columns: QTY, SIZE, TAG

Table with 3 columns: QTY, SIZE, TAG