



# MASON INDUSTRIES, Inc.

Manufacturers of Vibration Control Products

350 Rabro Drive 2101 W. Crescent Ave., Suite D  
 Hauppauge, NY 11788 Anaheim, CA 92801  
 631/348-0282 714/535-2727  
 FAX 631/348-0279 FAX 714/535-5738  
 Info@Mason-Ind.com Info@MasonAnaheim.com

JOB NAME \_\_\_\_\_  
 CUSTOMER \_\_\_\_\_  
 CUSTOMER P.O. \_\_\_\_\_  
 MASON M.I. \_\_\_\_\_  
 DWG. NO. \_\_\_\_\_

# EAFM

23785  
 ELASTOMERIC  
 ACOUSTICAL  
 FLOOR MOUNTS

### Material:

LDS, compounded to  
 Bridge-bearing pad specifications.

**EAFM 23785** Mounts are designed for 0.45" (11.4mm)  
 maximum deflection under constant load.

Temporary loading may greatly exceed these  
 numbers without damage or permanent set.

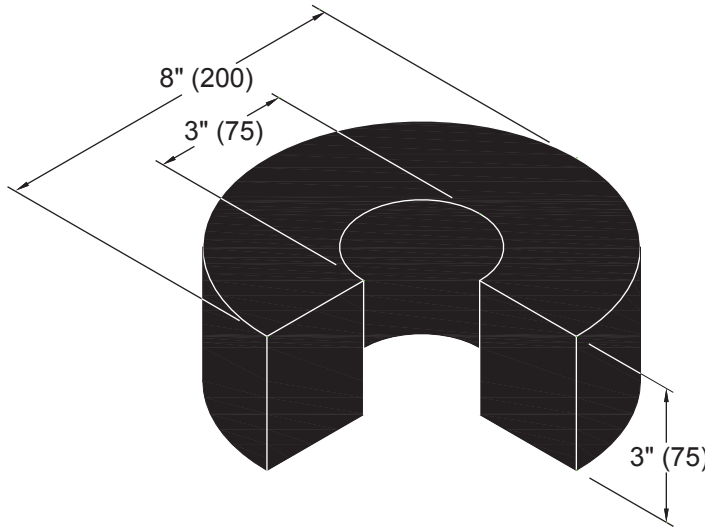

MASON LOW DYNAMIC STIFFNESS (LDS) BRIDGE BEARING COMPOUNDS. DYNAMIC NATURAL FREQUENCY/DEFLECTION CHART

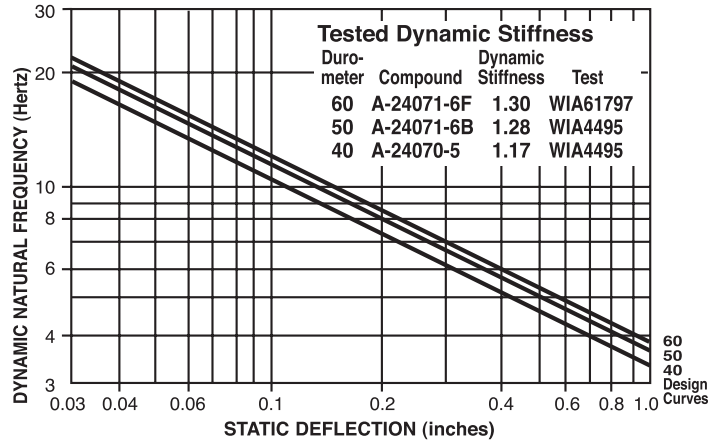

LOAD DEFLECTION CURVES  
 DEFLECTION (mm)

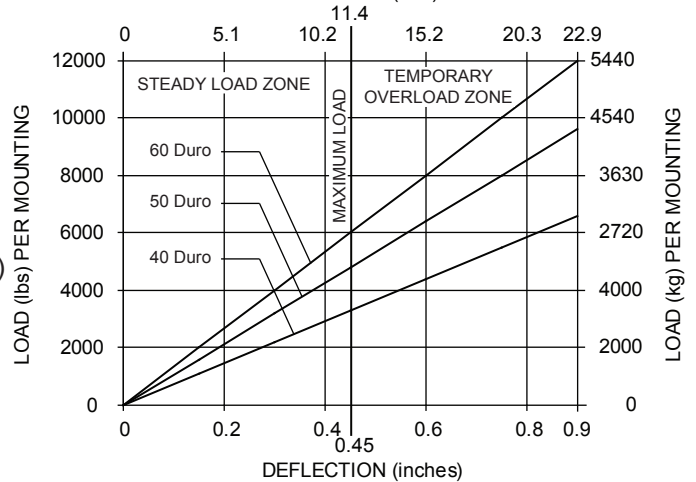

### CERTIFICATION DATA

Mason Layout Drawing :

### BRIDGE BEARING NATURAL RUBBER SPECIFICATIONS

ORIGINAL PHYSICAL PROPERTIES			TESTING FOR AGING				COMPRES-SION SET
(a)	(b)	(b)	(c)			(d)	(e)
Duro-meter	Tensile Strength [min]	Elongat. at Break [min]	Hard-ness [max]	Tensile Strength [max]	Elongat. at Break [min]	1 ppm in air by Vol. 20% Strain 100°F	22hrs/158°F Method B
40±5*	2000 psi	500%	+10%	-25%	-25%	No Cracks	25% (max)
50±5	2250 psi	450%	+10%	-25%	-25%	No Cracks	25% (max)
60±5	2250 psi	400%	+10%	-25%	-25%	No Cracks	25% (max)
70±5	2250 psi	300%	+10%	-25%	-25%	No Cracks	25% (max)

(a)ASTM D-2440 (b)ASTM D-412 (c)ASTM D-573 (d)ASTM D-1149 (e)ASTM D-395

\*AASHTO does notspec 40 Duro. 40 Duro by Mason.

EAFM Designation & Color	Duro-meter ± 5	Load Capacity (lbs kg)					
		Rated Load Range			Natural Frequency of Mounts with Dynamic Frequency Correction (Hz)		
		0.15" Defl. 3.8 mm	0.30" Defl. 7.6 mm	0.45" Defl. 11.4 mm	0.15" Defl. 3.8 mm	0.30" Defl. 7.6 mm	0.45" Defl. 11.4 mm
Green	40	1100 <b>500</b>	2200 <b>1000</b>	3300 <b>1500</b>	8.7	6.2	5.0
23785 Red	50	1600 <b>725</b>	3200 <b>1450</b>	4800 <b>2175</b>	9.1	6.5	5.2
White	60	2000 <b>910</b>	4000 <b>1820</b>	6000 <b>2730</b>	9.2	6.6	5.3