



# MASON INDUSTRIES, Inc.

Manufacturers of Vibration Control Products

350 Rabro Drive  
Hauppauge, NY 11788  
631/348-0282  
FAX 631/348-0279  
Info@Mason-Ind.com

2101 W. Crescent Ave., Suite D  
Anaheim, CA 92801  
714/535-2727  
FAX 714/535-5738  
Info@MasonAnaheim.com  
www.Mason-Ind.com

JOB NAME \_\_\_\_\_  
CUSTOMER \_\_\_\_\_  
CUSTOMER P.O. \_\_\_\_\_  
MASON M. \_\_\_\_\_  
DWG No. \_\_\_\_\_

# EAFM

8452 & 8846  
Elastomeric  
Acoustical  
Floor Mounts

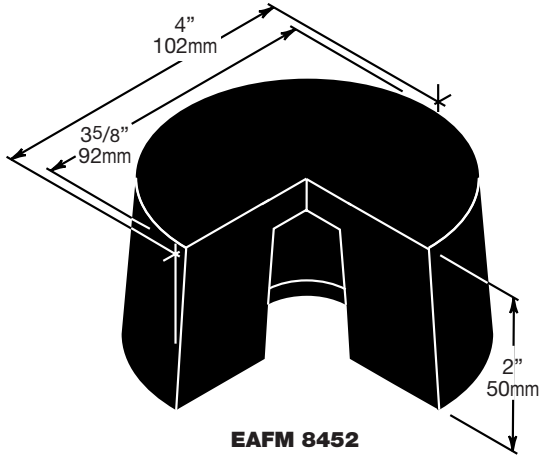

**EAFM 8452**

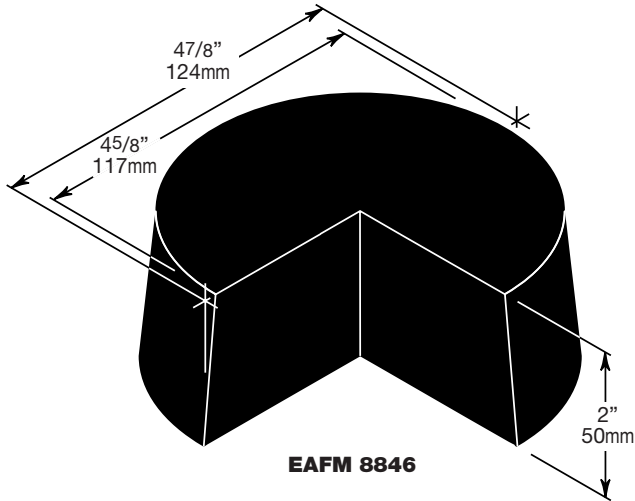

**EAFM 8846**

**Material:**

LDS Rubber, compounded to AASHTO Bridge-bearing specifications.

LDS stands for **Low Dynamic Stiffness** AASHTO Bridge Bearing Natural Rubber to minimize noise and vibration transmission. Maximum Dynamic Stiffness is 1.4.

Mounts are designed for 0.3" 7.6mm maximum deflection under constant load.

Temporary loading may greatly exceed these numbers without damage or permanent set.

**MASON LOW DYNAMIC STIFFNESS (LDS) BRIDGE BEARING NATURAL RUBBER DYNAMIC NATURAL FREQUENCY/DEFLECTION CHART**

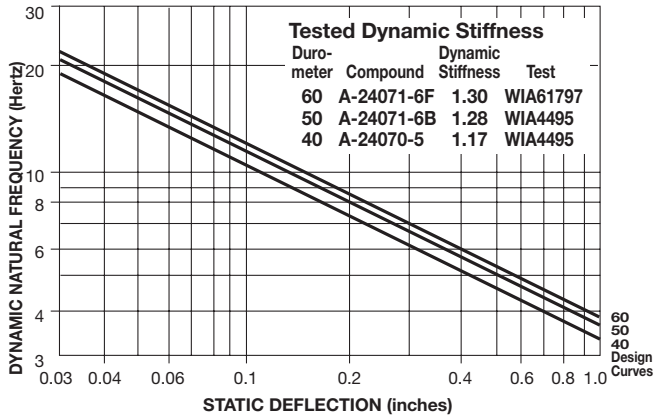

**LOAD DEFLECTION CURVES**

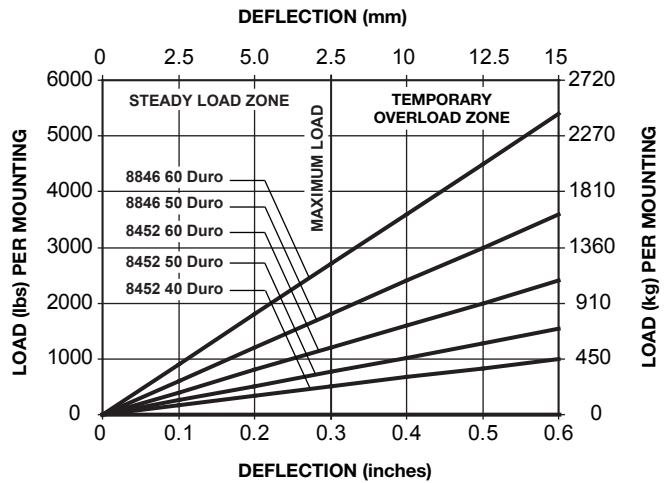

**AASHTO BRIDGE BEARING NATURAL RUBBER SPECIFICATIONS**

ORIGINAL PHYSICAL PROPERTIES			TESTED FOR AGING			COMPRESSION SET	LONG TERM CREEP	
Duro-meter	Tensile Strength	Elongat. at Break	OVEN AGING (70hrs/158°F)	ASTM D-573	OZONE			ASTM D-395
Tests: ASTM D-2240 & D-412								
Shore A (min)	Strength (min)	at Break (min)	Hard-ness (max)	Tensile Strength (max)	Elongat. at Break (max)	25 pphm in air by Vol. 20% Strain 100°F	22hrs/158°F Method B	168hrs
40±5	2000 psi	500%	+10%	-25%	-25%	No Cracks	25%(max)	5%(max)
50±5	2250 psi	450%	+10%	-25%	-25%	No Cracks	25%(max)	5%(max)
60±5	2250 psi	400%	+10%	-25%	-25%	No Cracks	25%(max)	5%(max)
70±5	2250 psi	300%	+10%	-25%	-25%	No Cracks	25%(max)	5%(max)

NOTE: AASHTO does not spec 40 Duro. 40 Duro by Mason.

Mason Layout Drawing:

EAFM Designation & Color	Durometer ±5	0.1" 2.5mm Deflection		0.2" 5.1mm Deflection		0.3" 7.6mm Deflection		Temporary Overload* 3X Maximum Loading	
		Loading lbs.	Frequency kgs. Hz	Loading lbs.	Frequency kgs. Hz	Loading lbs.	Frequency kgs. Hz		
8452	Green 40	167	76	333	151	500	227	1500	681
	Red 50	256	116	513	233	770	350	2310	1050
	White 60	400	182	800	364	1200	545	3600	1636
8846	Red 50	600	273	1200	545	1800	818	5400	2454
	White 60	900	409	1800	817	2700	1227	8100	3681

\*Temporary overload is often mentioned in specifications. We have tested mountings compressed to 50% of their initial thickness. After release there was no permanent set or damage.