



MASON INDUSTRIES, Inc.

MERCER RUBBER Co.

350 Rabro Drive, Hauppauge, NY 11788
Mason- 631/348-0282 • Info@Mason-Ind.com
Mercer- 631/582-1524 • Info@Mercer-Rubber.com
FAX 631/348-0279



JOB NAME _____
CUSTOMER _____
CUSTOMER P.O. _____
MASON M. _____
DWG No. _____

FCFUSS-NSF

SS BRAIDED HOSE
with FEMALE
COUPLING and
FEMALE UNION

ALL COMPONENTS STAINLESS STEEL

Full Vacuum Rating- 30" (762mm) Hg

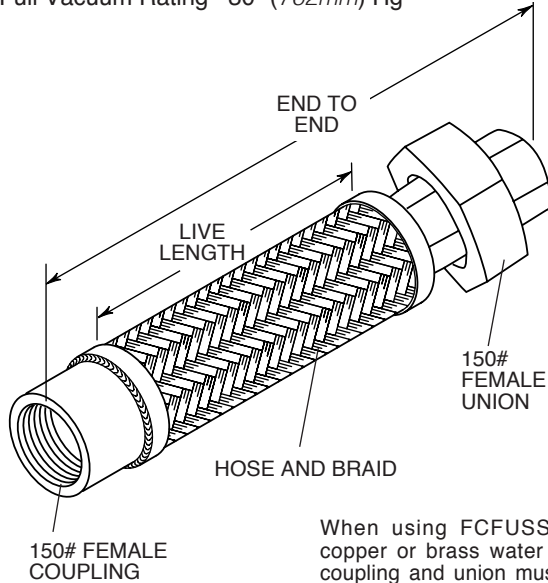

Conforms to UL and ANSI/NSF 61
Approved Temperature Range.

FCFU has a female coupling
on one end and a female
union on the other end.



WATER QUALITY
DRINKING WATER
SYSTEM COMPONENT
ANNEX G of ANSI / NSF 61
(4RV6)

These flexible joint fitting assemblies are UL Listed under File MH48651 and are intended for installation in accordance with the Mason installation instructions and the applicable requirements in Annex G of ANSI/NSF 61.

Mason Industries ensures for all UL Listed Products:

- 1. All hose dimensions meet our specifications and dimensions as tabulated.
- 2. Each assembly is pressure tested using Nitrogen Gas for 1 minute at 1 1/2 times the rated working pressure with no leaks.
- 3. A metal tag is attached which shows the UL Mark and Identification Number, our name, the location (US), and the Part Number with the approval date (month and year).
- 4. Two product stickers which show the UL Mark and Identification Number are on each shipping crate.

When using FCFUSS-NSF products in copper or brass water systems, dielectric coupling and union must be used on each end to prevent leakage from galvanic action.

FCFUSS-NSF DIMENSIONS AND PRESSURE RATINGS (American Units)

Pipe Size & End to End (in)	Live Length (in)	Corrugations per foot	Maximum Permanent Lateral Offset (in)	Rated Pressure @70°F (psi)
1/2 x 12	73/4	92	11/4	1100
1/2 x 18	133/4	92	21/2	1100
1/2 x 24	193/4	92	31/2	1100
3/4 x 12	73/4	80	1	700
3/4 x 18	133/4	80	21/4	700
3/4 x 24	193/4	80	31/4	700
1 x 12	73/4	72	3/4	580
1 x 18	133/4	72	2	580
1 x 24	193/4	72	3	580
1 1/4 x 12	63/4	67	5/8	480
1 1/4 x 18	123/4	67	13/4	480
1 1/4 x 24	183/4	67	23/4	480
1 1/2 x 12	63/4	63	1/2	450
1 1/2 x 18	123/4	63	11/2	450
1 1/2 x 24	183/4	63	21/2	450
2 x 14	6	58	3/8	360
2 x 18	12	58	13/8	360
2 x 24	18	58	23/8	360
2 1/2 x 18	11	48	11/4	290
2 1/2 x 24	17	48	2	290
3 x 18	11	46	1	280
3 x 24	17	46	13/4	280
3 x 36	29	46	33/4	280
4 x 18	11	32	1/2	225
4 x 24	17	32	3/4	225
4 x 36	29	32	31/4	225

FCFUSS-NSF DIMENSIONS AND PRESSURE RATINGS (Metric Units)

Pipe Size & End to End (mm)	Live Length (mm)	Corrugations per meter	Maximum Permanent Lateral Offset (mm)	Rated Pressure @21°C (kg/cm²)
15 x 305	197	32	302	77
15 x 457	349	63	302	77
15 x 610	502	88	302	77
20 x 305	197	25	262	49
20 x 457	349	57	262	49
20 x 610	502	83	262	49
25 x 305	194	19	236	40
25 x 457	349	50	236	40
25 x 610	502	75	236	40
32 x 305	171	16	220	33
32 x 457	324	44	220	33
32 x 610	476	70	220	33
40 x 305	171	13	207	31
40 x 457	324	38	207	31
40 x 610	476	63	207	31
50 x 356	152	10	190	25
50 x 457	305	35	190	25
50 x 610	457	60	190	25
65 x 457	279	32	157	20
65 x 610	432	50	157	20
80 x 457	279	25	151	19
80 x 610	432	44	151	19
80 x 914	737	95	151	19
100 x 457	279	13	105	15
100 x 610	432	19	105	15
100 x 914	737	83	105	15

End to End Tolerance: minus 1% plus 3%. Minimum Burst is four times the Rated Pressure. Safety factor of 4.
Lateral Offset one side of centerline and normal machinery vibration. If intermittent in both directions, reduce by 50%.

QTY	SIZE	TAG

QTY	SIZE	TAG