



MASON INDUSTRIES, Inc.

MERCER RUBBER Co.

350 Rabro Drive, Hauppauge, NY 11788  
 Mason- 631/348-0282 • Info@Mason-Ind.com  
 Mercer- 631/582-1524 • Info@Mercer-Rubber.com  
 FAX 631/348-0279



JOB NAME \_\_\_\_\_  
 CUSTOMER \_\_\_\_\_  
 CUSTOMER P.O. \_\_\_\_\_  
 MASON M. \_\_\_\_\_  
 DWG No. \_\_\_\_\_

**FFLSS-NSF**

SS BRAIDED  
 HOSE with  
**FIXED &  
 FLOATING  
 FLANGES**

**ALL COMPONENTS STAINLESS STEEL**

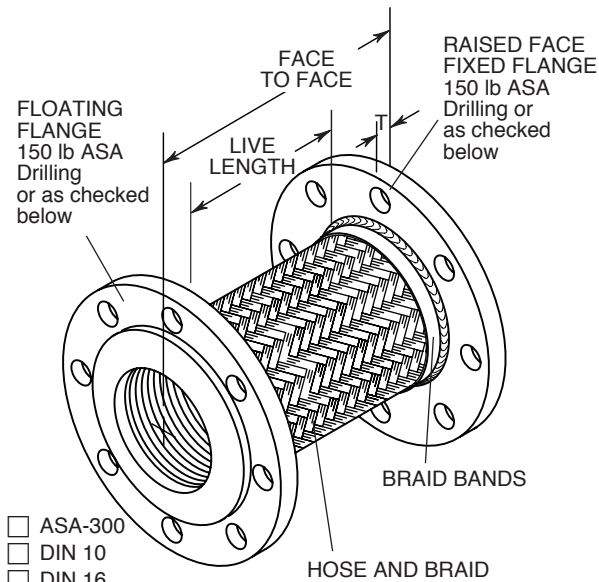

- ASA-300
- DIN 10
- DIN 16
- DIN 25

**PLATE FLANGE THICKNESS**

Pipe Size (in)	Pipe Size (mm)	Flange Thickness T (in)	Flange Thickness T (mm)
1 1/2 thru 4	40 thru 100	5/8	16
5 thru 6	125 thru 150	3/4	19
8 thru 16	200 thru 400	1	25

When using FFLSS-NSF products in copper or brass water systems, dielectric flanges must be used on each end to prevent leakage from galvanic action.

**Industry Standard Pump Connectors**  
 Short lengths conserve space but allow minimum motion and attenuation.  
**Offset Ratings are industry standard.**



**WATER QUALITY**  
 DRINKING WATER SYSTEM COMPONENT  
 ANNEX G of ANSI / NSF 61 (4RV6)

These flexible joint fitting assemblies are UL Listed under File MH48651 and are intended for installation in accordance with the Mason installation instructions and the applicable requirements in Annex G of ANSI/NSF 61.

Mason Industries ensures for all UL Listed Products:

- All hose dimensions meet our specifications and dimensions as tabulated.
- Each assembly is pressure tested using Nitrogen Gas for 1 minute at 1 1/2 times the rated working pressure with no leaks.
- A metal tag is attached which shows the UL Mark and Identification Number, our name, the location (US), and the Part Number with the approval date (month and year).
- Two product stickers which show the UL Mark and Identification Number are on each shipping crate.

Conforms to UL and ANSI/NSF 61 Approved Temperature Range.

Full Vacuum Rating— 30" (762mm) Hg

**FFLSS-NSF DIMENSIONS AND PRESSURE RATINGS (American Units)**

Type	Pipe Size & Face to Face (in)	Live Length (in)	Corrugations per foot	Maximum Permanent Lateral Offset (in)	Rated Pressure @70°F (psi)
FFLSS-NSF	1 1/2 X 9	67/8	63	1/8	450
FFLSS-NSF	2 X 9	61/8	58	1/8	360
FFLSS-NSF	2 1/2 X 9	61/8	48	1/8	290
FFLSS-NSF	3 X 9	61/8	46	1/8	280
FFLSS-NSF	4 X 9	61/8	32	1/8	225
FFLSS-NSF	5 X 12	87/8	29	1/8	200
FFLSS-NSF	6 X 12	87/8	25	1/8	200
FFLSS-NSF	8 X 12	85/8	23	1/8	200
FFLSS-NSF	10 X 13	95/8	21	1/8	170
FFLSS-NSF	12 X 14	105/8	20	1/8	170
FFLSS-NSF	14 X 14	105/8	18	1/8	170
FFLSS-NSF	16 X 16	125/8	16	1/8	170

**FFLSS-NSF DIMENSIONS AND PRESSURE RATINGS (Metric Units)**

Type	Pipe Size & Face to Face (mm)	Live Length (mm)	Corrugations per meter	Maximum Permanent Lateral Offset (mm)	Rated Pressure @21°C (kg/cm²)
FFLSS-NSF	40 X 229	175	207	3	31
FFLSS-NSF	50 X 229	156	190	3	25
FFLSS-NSF	65 X 229	156	157	3	20
FFLSS-NSF	80 X 229	156	151	3	19
FFLSS-NSF	100 X 229	156	105	3	15
FFLSS-NSF	125 X 305	225	95	3	14
FFLSS-NSF	150 X 305	225	82	3	14
FFLSS-NSF	200 X 305	219	75	3	14
FFLSS-NSF	250 X 330	244	69	3	11
FFLSS-NSF	300 X 356	270	66	3	11
FFLSS-NSF	350 X 356	270	59	3	11
FFLSS-NSF	400 X 406	321	52	3	11

Face to Face Tolerance: minus 1% plus 3%. Minimum Burst is four times the Rated Pressure. Safety factor of 4.  
 Lateral Offset one side of centerline and normal machinery vibration. If intermittent in both directions, reduce by 50%.  
 Sizes 12" - 16" (300-400mm) have double braid.

QTY	SIZE	TAG

QTY	SIZE	TAG



MASON INDUSTRIES, Inc.

MERCER RUBBER Co.

350 Rabro Drive, Hauppauge, NY 11788
Mason- 631/348-0282 • Info@Mason-Ind.com
Mercer- 631/582-1524 • Info@Mercer-Rubber.com
FAX 631/348-0279



JOB NAME
CUSTOMER
CUSTOMER P.O.
MASON M.
DWG No.

FFLSS-NSF

SS BRAIDED HOSE with FIXED & FLOATING FLANGES

ALL COMPONENTS STAINLESS STEEL

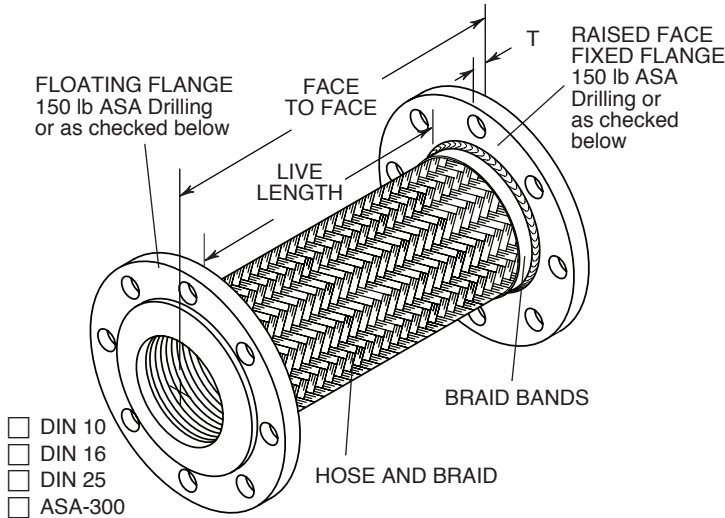

- DIN 10
DIN 16
DIN 25
ASA-300



WATER QUALITY DRINKING WATER SYSTEM COMPONENT ANNEX G of ANSI / NSF 61 (4RV6)

These flexible joint fitting assemblies are UL Listed under File MH48651 and are intended for installation in accordance with the Mason installation instructions and the applicable requirements in Annex G of ANSI/NSF 61.

Mason Industries ensures for all UL Listed Products:

- 1. All hose dimensions meet our specifications and dimensions as tabulated.
2. Each assembly is pressure tested using Nitrogen Gas for 1 minute at 1 1/2 times the rated working pressure with no leaks.
3. A metal tag is attached which shows the UL Mark and Identification Number, our name, the location (US), and the Part Number with the approval date (month and year).
4. Two product stickers which show the UL Mark and Identification Number are on each shipping crate.

Conforms to UL and ANSI/NSF 61 Approved Temperature Range.

Full Vacuum Rating- 30" (762mm) Hg

When using FFLSS-NSF products in copper or brass water systems, dielectric flanges must be used on each end to prevent leakage from galvanic action.

PLATE FLANGE THICKNESS

Table with 3 columns: Pipe Size (in), Pipe Size (mm), Flange Thickness T (in) (mm). Rows include sizes from 1 1/2 thru 4 to 8 thru 16.

Face to Face Tolerance: minus 1% plus 3%. Minimum Burst is four times the Rated Pressure. Safety factor of 4. Lateral Offset one side of centerline and normal machinery vibration. If intermittent in both directions, reduce by 50%. Sizes 12" - 16" (300-400mm) have double braid.

FFLSS-NSF DIMENSIONS AND PRESSURE RATINGS (American Units)

Table with 5 columns: Pipe Size & Face to Face (in), Live Length (in), Corrugations per foot, Maximum Permanent Lateral Offset (in), Rated Pressure @70°F (psi). Rows include sizes from 1 1/2 X 12 to 16 X 36.

FFLSS-NSF DIMENSIONS AND PRESSURE RATINGS (Metric Units)

Table with 5 columns: Pipe Size & Face to Face (mm), Live Length (mm), Corrugations per meter, Maximum Permanent Lateral Offset (mm), Rated Pressure @21°C (kg/cm²). Rows include sizes from 40 X 305 to 400 X 914.

Table with 3 columns: QTY, SIZE, TAG

Table with 3 columns: QTY, SIZE, TAG