



MASON INDUSTRIES, Inc.

MERCER RUBBER Co.

350 Rabro Drive, Hauppauge, NY 11788
Mason- 631/348-0282 • Info@Mason-Ind.com
Mercer- 631/582-1524 • Info@Mercer-Rubber.com
FAX 631/348-0279



JOB NAME
CUSTOMER
CUSTOMER P.O.
MASON M.
DWG No.

GWNSS-NSF

SS BRAIDED HOSE
with GROOVED
WELD NIPPLES

ALL COMPONENTS STAINLESS STEEL

Full Vacuum Rating- 30" (762mm) Hg

Conforms to UL and ANSI/NSF 61
Approved Temperature Range.



CLASSIFIED
UL US
WATER QUALITY
DRINKING WATER
SYSTEM COMPONENT
ANNEX G of ANSI / NSF 61
(4RV6)

SCHEDULE 40
NIPPLES grooved
for couplings
and beveled for
welding alternate

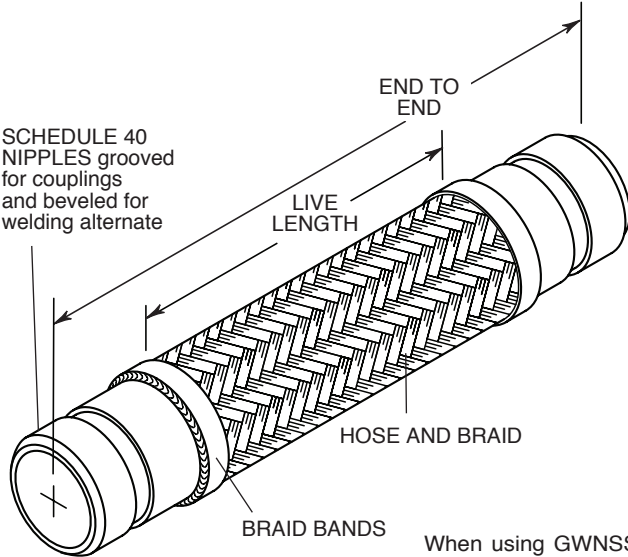

When using GWNSS-NSF products
in copper or brass water systems,
dielectric couplings must be used on
each end to prevent leakage from
galvanic action.

These flexible joint fitting assemblies are UL Listed under
File MH48651 and are intended for installation in accordance
with the Mason installation instructions and the applicable
requirements in Annex G of ANSI/NSF 61.

Mason Industries ensures for all UL Listed Products:

- 1. All hose dimensions meet our specifications and dimensions as tabulated.
2. Each assembly is pressure tested using Nitrogen Gas for 1 minute at 1 1/2 times the rated working pressure with no leaks.
3. A metal tag is attached which shows the UL Mark and Identification Number, our name, the location (US), and the Part Number with the approval date (month and year).
4. Two product stickers which show the UL Mark and Identification Number are on each shipping crate.

GWNSS-NSF DIMENSIONS AND PRESSURE RATINGS (American Units)

Table with 6 columns: Type, Pipe Size & End to End (in), Live Length (in), Corrugations per foot, Maximum Permanent Lateral Offset(in), Rated Pressure @70°F (psi)

GWNSS-NSF DIMENSIONS AND PRESSURE RATINGS (Metric Units)

Table with 6 columns: Type, Pipe Size & End to End (mm), Live Length (mm), Corrugations per meter, Maximum Permanent Lateral Offset(mm), Rated Pressure @21°C (kg/cm²)

End to End Tolerance: minus 1% plus 3%. Minimum Burst is four times the Rated Pressure. Safety factor of 4.
Lateral Offset one side of centerline and normal machinery vibration. If intermittent in both directions, reduce by 50%.
Size 12" (300mm) has double braid.

Table with 3 columns: QTY, SIZE, TAG

Table with 3 columns: QTY, SIZE, TAG

Certification Form S-5056 07/2013 DWN CHKD DATE DWG No.