



MASON INDUSTRIES, Inc.

Manufacturers of Vibration Control Products

350 Rabro Drive
Hauppauge, NY 11788
631/348-0282
FAX 631/348-0279
Info@Mason-Ind.com

2101 W. Crescent Ave., Suite D
Anaheim, CA 92801
714/535-2727
FAX 714/535-5738
Info@MasonAnaheim.com
www.Mason-Ind.com

JOB NAME _____
CUSTOMER _____
CUSTOMER P.O. _____
MASON M. _____
DWG No. _____

PC30

1" 25mm Deflection
X, A, B, C, D & F
Precompressed
Ceiling Hangers

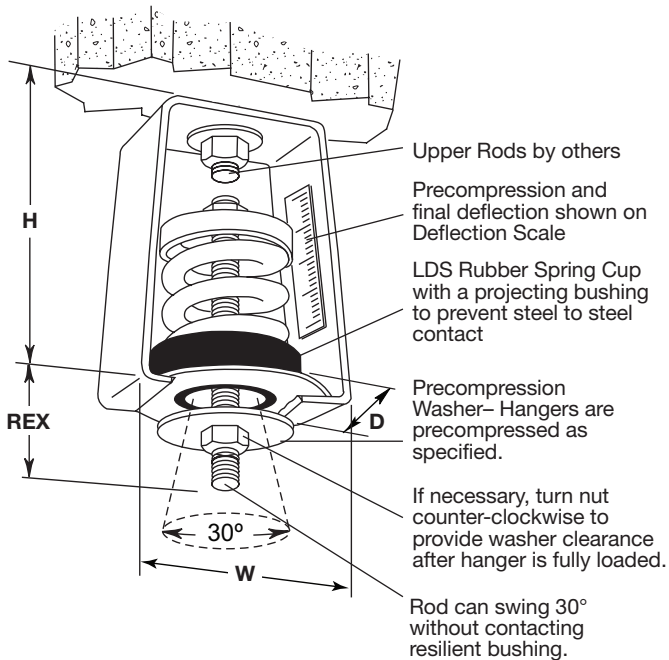

LDS stands for Low Dynamic Stiffness Bridge Bearing Natural Rubber to minimize noise and vibration transmission.

TYPE PC30 RATINGS

Type and Size	Rated Capacity (lbs) (kg)		Rated Deflection (in) (mm)		Spring Constant (lbs/in) (kg/mm)		Spring Color
PC30-X-23	23	10	1.50	33	18	0.3	Brown
PC30-X-33	33	15	1.30	28	30	0.5	Red
PC30-X-54	54	24	1.40	31	45	0.8	White
PC30-X-76	76	34	1.22	26	73	1.3	Black
PC30-X-113	113	51	1.20	25	113	2.0	Yellow
PC30-X-130	130	59	1.20	25	130	2.3	Purple
PC30-X-175	175	79	1.20	25	175	3.1	Silver
PC30-X-210	210	95	1.20	25	210	3.8	Blue
PC30-A-12	12	5	1.00	25	12	0.2	Red
PC30-A-18	18	8	1.00	25	18	0.3	Gray
PC30-A-25	25	11	1.00	25	25	0.4	Orange
PC30-A-41	41	19	1.18	30	35	0.6	Pink
PC30-A-56	56	25	1.14	29	49	0.9	Black
PC30-A-73	73	33	1.06	27	69	1.2	Tan
PC30-A-95	95	43	1.01	26	94	1.7	Green
PC30-B-138	138	63	1.32	34	105	1.9	White
PC30-B-222	222	101	1.16	30	191	3.4	Blue
PC30-B-278	278	126	1.09	28	255	4.6	Purple
PC30-B-336	336	152	1.00	25	336	6.0	Silver
PC30-B-410	410	186	1.07	27	385	6.9	Black
PC30-B-540	540	245	1.00	25	540	9.6	Yellow
PC30-C-630	630	286	1.13	29	558	10.0	Gray
PC30-C-800	800	363	1.00	25	800	14.3	Orange
PC30-C-1010	1010	458	1.10	28	920	16.4	Green
PC30-C-1265	1265	574	1.00	25	1265	22.6	Red
PC30-D-1575	1575	714	1.23	31	1280	22.9	Pink
PC30-D-2150	2150	975	1.03	26	2095	37.4	Purple
PC30-F-2760	2760	1252	1.00	25	2760	49.3	Silver

TYPE PC30 DIMENSIONS

Size Range	D (in) (mm)		H (in) (mm)		W (in) (mm)		REX (in) (mm)		MRD (in) (mm)	
PC30-X-23-210	2 1/2	64	4 1/4	108	2 7/8	73	1 3/4	89	3/8	10
PC30-A-12-25	2 3/4	70	5 3/4	146	3 1/4	83	2 1/4	89	1/2	13
PC30-A-41-95	2 3/4	70	5 3/4	146	3 1/4	83	2 1/4	102	1/2	13
PC30-B-138-540	4	102	7 1/4	184	4 3/4	121	2 3/4	108	5/8	16
PC30-C-630-1265	4	121	8 11/16	222	5 1/4	133	2 3/4	127	3/4	19
PC30-D-1575-2150	4 3/4	121	12 1/2	318	5 3/4	146	2 1/2	178	7/8	22
PC30-F-2760	6	152	12	305	6 1/4	159	2 1/2	178	7/8	22

REX - Rod Extension
MRD - Maximum Rod Diameter

All springs have additional travel to solid equal to 50% of the Rated Deflection.

PLAN VIEW OF HANGER LOCATIONS

TAG: _____
UNIT: _____



SPECIFIED DEFLECTION

1:	6:
2:	7:
3:	8:
4:	9:
5:	10:
Sets Required:	