



MASON INDUSTRIES, Inc.

Manufacturers of Vibration Control Products

350 Rabro Drive
Hauppauge, NY 11788
631/348-0282
FAX 631/348-0279
Info@Mason-Ind.com
www.Mason-Ind.com

2101 W. Crescent Ave., Suite D
Anaheim, CA 92801
714/535-2727
FAX 714/535-5738
Info@MasonAnaheim.com
www.MasonAnaheim.com

**CAPTIVE SPRING
MOUNT for SEISMIC
and RESTRAINED
SERVICE 1" (25mm) &
2" (50mm) DEFLECTION**

**TYPE
SSLFH**
DATA SHEET DS-203-6.2

1" (25mm) Deflection Spring Series

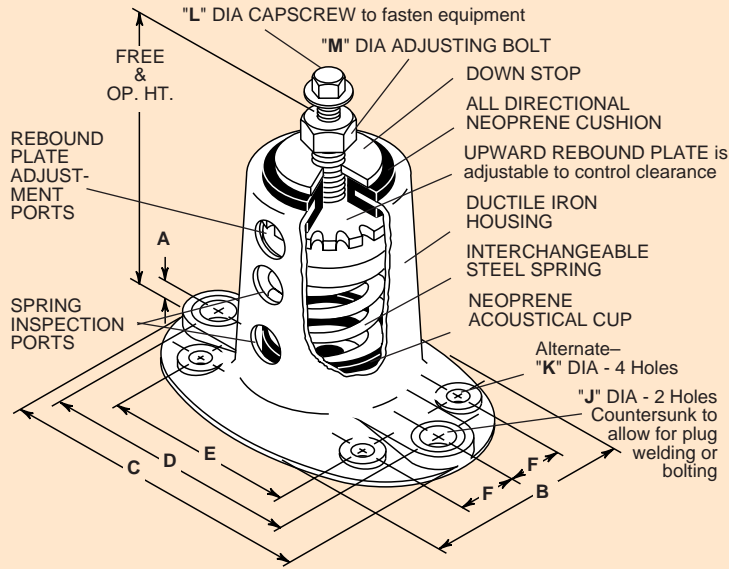

TYPE SSLFH DIMENSIONS (inches mm)

Size	A	B	C	D	E	F	J	K	L	M	Free & Op Ht
SSLFH-A	1/4	4	6 1/4	4 3/4	4	1 1/8	3/4	1/2	3/8	3/4	6
SSLFH-B	1/2	6	9 1/4	7 1/2	5 1/2	1 5/8	3/4	5/8	1/2	7/8	7 1/2
SSLFH-C	1/2	7	11	9	6	2	7/8	3/4	5/8	1	8
SSLFH-A	6	102	159	121	102	29	19	13	10	19	152
SSLFH-B	13	152	235	191	140	41	19	16	13	22	191
SSLFH-C	13	178	279	229	152	51	22	19	16	25	203

PLUG WELDED RATINGS

Size	Horizontal (lbs) (kg)	Vertical (lbs) (kg)
SSLFH-A	1650 748	5500 2495
SSLFH-B	3100 1406	4345 1971
SSLFH-C	3800 1724	5630 2554

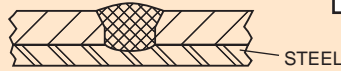

TYPICAL PLUG WELD

Plug Welded Testing and Calculations were performed to meet OSHPD criteria.

INSTALLATION INSTRUCTIONS

1. Remove cap screw "L" and place mountings under hole in equipment base.
2. If supports are badly off level, shim mounting level before securing.
3. Pass cap screw "L" through hole in equipment base and screw loosely into adjusting bolt "M".
4. Repeat this procedure in all mounting locations.
5. Keep "Upward Rebound Plate" from turning by restraining it with a screw driver through the adjustment port.

SPECIFICATION

Equipment shall be installed on resilient mountings designed and rated to resist seismic forces in all directions. The snubber shall be adjustable in the vertical up direction and allow a maximum of 1/4" (6mm) travel in the vertical and horizontal direction before contacting the resilient snubbing collars. Mountings shall have an Anchorage Preapproval "OPA" Number from OSHPD in the state of California attesting to the minimum listed certified Horizontal and Vertical load ratings.

All mountings shall have adjusting bolts that are rigidly bolted to the equipment.

6. Take two full counter-clockwise turns on each adjusting bolt "M" and continue even adjustment of all mounts until all springs are loaded and mountings are back to Free and Operating Height.
7. Take no more than two additional counter-clockwise turns on any "M" adjusting bolt to level equipment.
8. Tighten cap screws "L" to secure equipment.
9. Turn rebound plate clockwise to lower or counter-clockwise to raise. Adjust plate so there is 1/8" (3mm) clearance between top of plate and underside of all directional neoprene cushion.

Spring diameters shall be no less than 0.8 of the compressed height of the spring at rated load. Springs shall have a minimum additional travel to solid equal to 50% of the rated deflection. Mountings shall have a minimum of 2 spring inspection ports. Submittals shall include spring diameters, deflections, and calculations signed by a registered engineer showing that the seismic loads the mountings are to resist have been properly calculated. Mountings shall be Type SSLFH as manufactured by Mason Industries, Inc.

TYPE SSLFH RATINGS

Size	Rated Capacity (lbs) (kg)	Rated Defl (in) (mm)	Mount Constant (lbs/in)(kg/mm)	Spring Color/Stripe	Max. G Rating
SSLFH-A-45	45 20	1.60 41	28 0.5	Blue	37.8
SSLFH-A-75	75 34	1.50 38	50 0.9	Orange	22.7
SSLFH-A-125	125 57	1.33 34	94 1.7	Brown	13.6
SSLFH-A-200	200 91	1.15 29	174 3.1	Black	8.5
SSLFH-A-310	310 141	1.00 25	310 5.6	Yellow	5.5
SSLFH-A-400	400 181	1.00 25	400 7.2	Green	4.3
SSLFH-A-510	510 231	1.00 25	510 9.2	Red	3.3
SSLFH-A-625	625 283	1.00 25	625 11.3	White	2.7
SSLFH-B-65	65 29	2.10 53	31 0.6	Brown	47.7
SSLFH-B-85	85 39	2.10 53	40 0.7	White*	36.5
SSLFH-B-115	115 52	2.00 51	57 1.0	Silver	27.0
SSLFH-B-150	150 68	2.00 51	75 1.3	Orange	20.7
SSLFH-B-280	280 127	1.60 41	174 3.1	Green	11.1
SSLFH-B-450	450 204	1.31 33	344 6.2	Red	6.9
SSLFH-B-750	750 340	1.12 28	670 12.1	White	4.1
SSLFH-B-1000	1000 454	1.00 25	1000 18.2	Blue	3.1
SSLFH-B-1250	1250 567	1.00 25	1250 22.7	Gray	2.5
SSLFH-B-1650	1650 748	1.00 25	1650 30.0	Black	1.9
SSLFH-C-1000	1000 454	1.00 25	1000 18.2	Black	3.8
SSLFH-C-1350	1350 612	1.00 25	1350 24.5	Yellow	2.8
SSLFH-C-1750	1750 794	1.00 25	1750 31.8	Black*	2.2
SSLFH-C-2100	2100 953	1.00 25	2100 38.1	Yellow*	1.8
SSLFH-C-2385	2385 1082	1.00 25	2385 43.3	Yellow**	1.6
SSLFH-C-2650	2650 1202	1.00 25	2650 48.1	Red*	1.4
SSLFH-C-2935	2935 1331	1.00 25	2935 53.2	Red**	1.3

*with Black stripe *with Red inner spring **with Green inner spring

SPRING DATA

Size	Spring OD (in) (mm)	Free Ht. (in) (mm)	Ratio Kx/Ky	Ratio OD/OH
A-45-400	1 3/4 44	3 76	0.70-0.90	0.88-1.25
A-510-625	1 3/4 44	3 1/8-3 3/8 79-86	0.50-0.60	0.74-0.82
B	2 3/8 60	4 102	0.65-0.90	0.76-1.25
C	2 7/8 73	4 1/8 105	0.90-1.00	0.92

OSHPD OPA-0198 Rated Load Curves (lbs kg)†

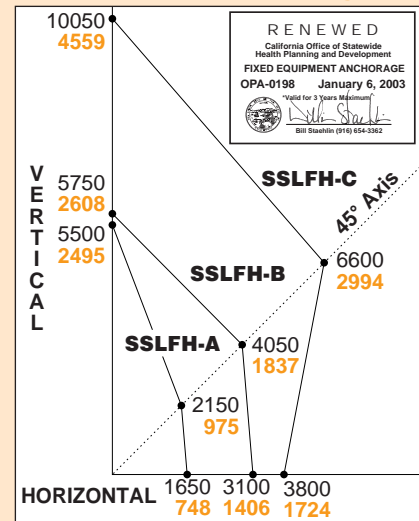

†For Kn divide Kg by 102.

Horizontal, Vertical and 45° plotted Ratings are California OSHPD approved values having the OSHPD Anchorage Preapproval Number OPA-0198. Testing and calculations were performed to meet OSHPD criteria.

To use approved OSHPD rated load curves:

- 1) Calculate Vertical and Horizontal Forces on mountings including translations and overturning moments.
- 2) Plot Horizontal Load vs Vertical Load. The point must fall within the area below the OSHPD curve.

2"(50mm) Deflection Spring Series

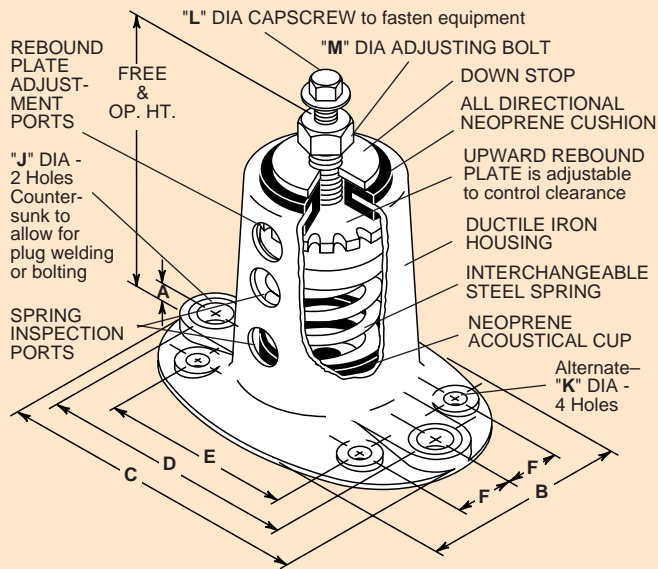

TYPE SSLFH RATINGS

Size	Rated Capacity (lbs) (kg)	Rated Defl (in)(mm)	Mount Constant (lbs/in)(kg/mm)	Spring Color/Stripe	Max. G Rating
SSLFH-B-20	20 9	2.40 61	8 0.1	Tan	155.0
SSLFH-B-26	26 12	2.18 55	12 0.2	White/Blue	119.2
SSLFH-B-35	35 16	2.20 56	16 0.3	Purple	88.6
SSLFH-B-50	50 23	2.20 56	24 0.4	White/Red	62.0
SSLFH-B-65	65 30	2.10 53	31 0.6	Brown	47.7
SSLFH-B-85	85 39	2.10 53	40 0.7	White/Black	36.5
SSLFH-B-115	115 52	2.00 51	57 1.0	Silver	27.0
SSLFH-B-150	150 68	2.00 51	75 1.3	Orange	20.7
SSLFH-B2-210	210 95	2.12 54	99 1.8	Silver	14.8
SSLFH-B2-290	290 131	2.00 51	144 2.6	Blue	10.7
SSLFH-B2-450 [†]	450 204	2.00 51	224 4.0	Tan	6.9
SSLFH-B2-680 [†]	680 308	2.00 51	340 6.0	Gray	4.6
SSLFH-C2-125	125 57	2.50 64	50 0.9	Purple	30.4
SSLFH-C2-170	170 77	2.40 61	70 1.3	Brown	22.4
SSLFH-C2-210	210 95	2.30 58	90 1.6	Red	18.1
SSLFH-C2-260	260 118	2.20 56	120 2.1	White	14.6
SSLFH-C2-330	330 150	2.00 51	165 2.9	Black	11.5
SSLFH-C2-460	460 209	2.00 51	230 4.1	Blue	8.3
SSLFH-C2-610	610 277	2.00 51	305 5.4	Green	6.2
SSLFH-C2-880 [†]	880 399	2.00 51	440 7.8	Gray	4.3
SSLFH-C2-1210 [†]	1210 549	2.00 51	605 10.8	Silver	3.1
SSLFH-C2-1540 [†]	1540 699	2.00 51	770 13.7	Gray*	2.5
SSLFH-C2-1870 [†]	1870 848	2.00 51	935 16.6	Silver*	2.0

*with RED inner spring

TYPE SSLFH DIMENSIONS (inches mm)

Size	A	B	C	D	E	F	J	K	L	M	Free & Op Ht
SSLFH-B&B2	1/2	6	9 1/4	7 1/2	5 1/2	1 5/8	3/4	5/8	1/2	7/8	7 1/2
SSLFH-C2	1/2	7	11	9	6	2	7/8	3/4	5/8	1	8
SSLFH-B&B2	13	152	235	191	140	41	19	16	13	22	191
SSLFH-C2	13	178	279	229	152	51	22	19	16	25	203

[†]Published ratings allow minimum 25% additional travel to solid. For a full 50% specified minimum use the following ratings:

Size	Derated Capacity (lbs) (kg)	Defl (in) (mm)	Size	Derated Capacity (lbs) (kg)	Defl (in) (mm)
B2-450	410 186	1.83 46.5	C2-1210	1010 458	1.67 42.4
B2-680	565 256	1.66 42.2	C2-1540	1285 583	1.67 42.4
C2-880	800 363	1.82 46.2	C2-1870	1560 708	1.67 42.4

PLUG WELDED RATINGS

Size	Horizontal (lbs) (kg)	Vertical (lbs) (kg)
SSLFH-B	3100 1406	4345 1971
SSLFH-C	3800 1724	5630 2554

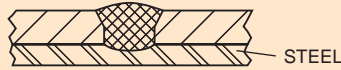

TYPICAL PLUG WELD

Plug Welded Testing and Calculations were performed to meet OSHPD criteria.

SPRING DATA

Size	Spring OD (in)(mm)	Free Ht. (in) (mm)	Ratio Kx/Ky	Ratio OD/OH
B & B2	23/8 60	4 102	0.65-0.90	0.76-1.25
C	27/8 73	4 1/8 105	0.90-1.00	0.92

INSTALLATION INSTRUCTIONS

1. Remove cap screw "L" and place mountings under hole in equipment base.
2. If supports are badly off level, shim mounting level before securing.
3. Pass cap screw "L" through hole in equipment base and screw loosely into adjusting bolt "M".
4. Repeat this procedure in all mounting locations.
5. Keep "Upward Rebound Plate" from turning by restraining it with a screw driver through the adjustment port.
6. Take two full counter-clockwise turns on each adjusting bolt "M" and continue even adjustment of all mounts until all springs are loaded and mountings are back to Free and Operating Height.
7. Take no more than two additional counter-clockwise turns on any "M" adjusting bolt to level equipment.
8. Tighten cap screws "L" to secure equipment.
9. Turn rebound plate clockwise to lower or counter-clockwise to raise. Adjust plate so there is 1/8"(3mm) clearance between top of plate and underside of all directional neoprene cushion.

SPECIFICATION

Equipment shall be installed on resilient mountings designed and rated to resist seismic forces in all directions. The snubber shall be adjustable in the vertical up direction and allow a maximum of 1/4" (6mm) travel in the vertical and horizontal direction before contacting the resilient snubbing collars. Mountings shall have an Anchorage Preapproval "OPA" Number from OSHPD in the state of California attesting to the minimum listed certified Horizontal and Vertical load ratings.

All mountings shall have adjusting bolts that are rigidly bolted to the equipment.

Spring diameters shall be no less than 0.8 of the compressed height of the spring at rated load. Springs shall have a minimum additional travel to solid equal to 50% of the rated deflection. Mountings shall have a minimum of 2 spring inspection ports. Submittals shall include spring diameters, deflections, and calculations signed by a registered engineer showing that the seismic loads the mountings are to resist have been properly calculated. Mountings shall be Type SSLFH as manufactured by Mason Industries, Inc.

OSHPD OPA-0198 Rated Load Curves (lbs kg)[†]

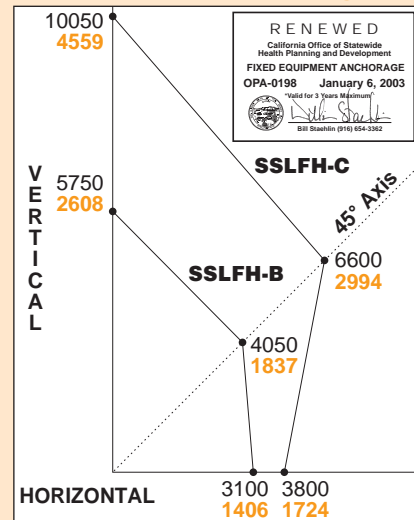

[†] For Kn divide Kg by 102.

Horizontal, Vertical and 45° plotted Ratings are California OSHPD approved values having the OSHPD Anchorage Preapproval Number OPA-0198. Testing and calculations were performed to meet OSHPD criteria.

To use approved OSHPD rated load curves:

- 1) Calculate Vertical and Horizontal Forces on mountings including translations and overturning moments.
- 2) Plot Horizontal Load vs Vertical Load. The point must fall within the area below the OSHPD curve.