



MASON INDUSTRIES, Inc.

Manufacturers of Vibration Control Products

350 Rabro Drive
Hauppauge, NY 11788
631/348-0282
FAX 631/348-0279
Info@Mason-Ind.com
www.Mason-Ind.com

2101 W. Crescent Ave., Suite D
Anaheim, CA 92801
714/535-2727
FAX 714/535-5738
Info@MasonAnaheim.com
www.MasonAnaheim.com

1" (25mm)

**DEFLECTION
X SPRING SERIES
SEISMIC MOUNTS**

TYPE

SSLFH-X

DATA SHEET DS-05A

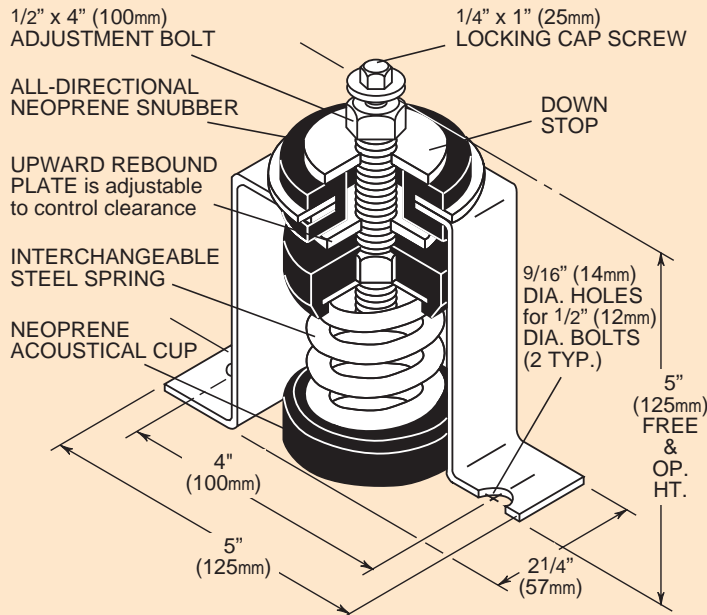

Mounts are galvanized.

OSHPD R-0199 Rated Load Curves (lbs kg)[†]

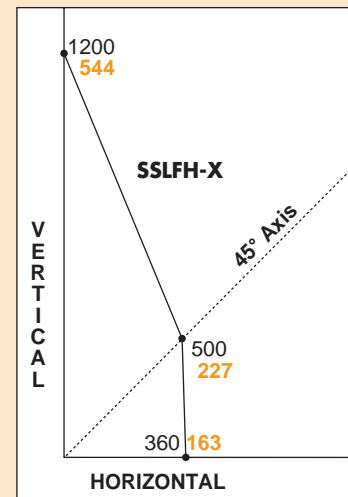

[†]For kN divide kg by 102

Horizontal and Vertical plotted Ratings are California OSHPD approved values having the OSHPD Anchorage Preapproval Number R-0199. Testing and calculations were performed to meet OSHPD criteria.

To use approved OSHPD rated load curves:

- 1) Calculate Vertical and Horizontal Forces on mountings including translations and overturning moments.
- 2) Plot Horizontal Load vs Vertical Load. The point must fall within the area below the OSHPD curve.

TYPE SSLFH RATINGS

Size	Rated Capacity (lbs) (kgs)	Rated Defl (in) (mm)	Mount Constant (lbs/in) (kg/mm)	Spring Color	Max Horiz. Static G Rating*
SSLFH-X-23	23 10	1.30 33	18 0.31	Brown	15.7
SSLFH-X-33	33 15	1.10 28	30 0.54	Red	10.9
SSLFH-X-54	54 25	1.20 30	45 0.82	White	6.7
SSLFH-X-76	76 35	1.02 26	73 1.33	Black	4.7
SSLFH-X-113	113 51	1.00 25	113 2.05	Yellow	3.2
SSLFH-X-130	130 59	1.00 25	130 2.36	Purple	2.8
SSLFH-X-175	175 79	1.00 25	175 3.20	Silver	2.1
SSLFH-X-210	210 95	1.00 25	210 3.82	Blue	1.7

*Horizontal G Ratings are for quick reference only—Use OSHPD Rated Load Curves.

SPRING DATA

Size	Spring OD (in)(mm)	Free Height (in)(mm)	Ratio Kx/Ky	Ratio OD/OH
23-130	1 1/2 38	23/8 60	0.86-1.00	1.09-1.40
175-210	1 1/2 38	25/8 66	0.75	0.92-1.00

INSTALLATION INSTRUCTIONS:

1. Remove locking cap screws and place mountings under holes in equipment base.
2. Shim mountings level before securing.
3. In all mounting locations, pass cap screws through holes in equipment base and screw loosely into leveling bolts.
4. Take two full counter-clockwise turns on each leveling bolt and continue even adjustment of all mounts until all springs are loaded and mountings are back to Free and Operating Height.
5. Take no more than two additional counter-clockwise turns on any leveling bolt to level equipment.
6. Tighten cap screws to secure equipment.
7. Adjust plates so there is 1/8" (3mm) clearance between top of plate and underside of all-directional neoprene cushion. Turn rebound plates clockwise to lower or counter-clockwise to raise.