



MASON INDUSTRIES, Inc.

MERCER RUBBER Co.

350 Rabro Drive, Hauppauge, NY 11788
 Mason- 631/348-0282 • Info@Mason-Ind.com
 Mercer- 631/582-1524 • Info@Mercer-Rubber.com
 FAX 631/348-0279



JOB NAME _____
 CUSTOMER _____
 CUSTOMER P.O. _____
 MASON M. _____
 DWG No. _____

VGWNS

**SPLIT 60°ve SS
 DOUBLE BRAIDED
 HOSE with CARBON
 STEEL GROOVED
 WELD NIPPLES**

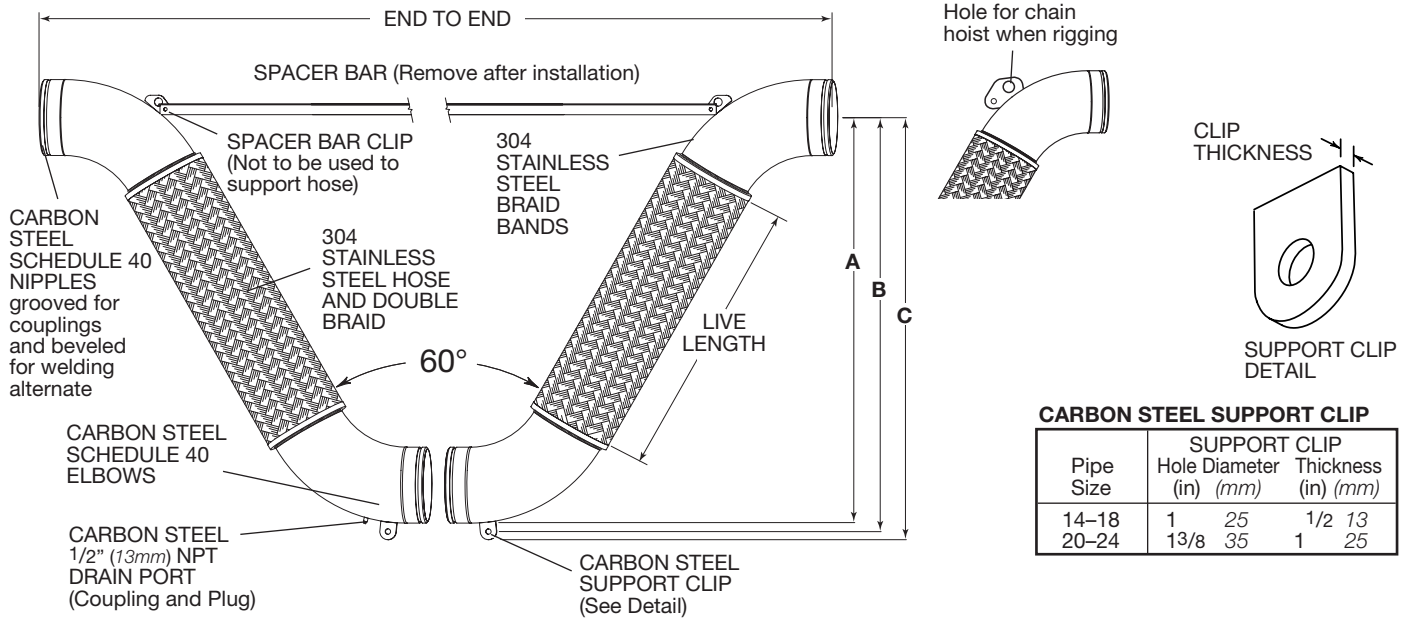

CARBON STEEL SUPPORT CLIP

Pipe Size	SUPPORT CLIP	
	Hole Diameter (in) (mm)	Thickness (in) (mm)
14-18	1 25	1/2 13
20-24	1 3/8 35	1 25

Drain Plugs are often removed to allow attachment of drain hose or steam trap for blow down or drainage.

Full Vacuum Rating- 30" (762mm) Hg

RATED PRESSURES @ ELEVATED TEMPERATURES (psi) (kg/cm²)

Pipe Size	250°F 121°C	350°F 176°C	450°F 232°C
	Factor 0.92	Factor 0.86	Factor 0.81
All	160 11	150 10	140 9

SATURATED STEAM RECOMMENDED PRESSURE LIMITS

Pipe Size	Max Gauge (psi) (kg/cm ²)		Temp Reference (°F) (°C)	
	All	60	4	307

Our steam service ratings are very low in the interest of safety although our 70°F (21°C) pressure ratings are as high or higher than our competitors. All locations where failure could lead to personal injury or suffocation must be avoided. In dangerous locations we suggest housed expansion joints, solid loops, ball joints, packed devices etc. rather than thin walled flexible products regardless of manufacturer.

Consult factory with full location description as well as service conditions for higher pressure or temperature applications.

304 SS can be used up to 850°F (454°C) in applications such as engine exhaust.

RATED MOVEMENTS

±4" (100mm) All Directional Seismic Movement
 ±6" (150mm) Guided Thermal Movement Only

VGWNS DIMENSIONS AND PRESSURE RATINGS (American Units)

Type	Pipe Size & End to End (in)	Live Length (in)	Corrugations per foot	Corrugations			Rated Pressure @70°F (psi)
				A (in)	B (in)	C (in)	
VGWNS	14 X 1423/4	52	18	743/4	761/2	78	170
VGWNS	16 X 1571/4	56	16	821/4	84	851/2	170
VGWNS	18 X 1791/2	68	15	965/8	985/8	997/8	170
VGWNS	20 X 194	72	15	104	1065/8	1081/8	170
VGWNS	24 X 2203/4	78	15	1113/8	114	1153/4	170

VGWNS DIMENSIONS AND PRESSURE RATINGS (Metric Units)

Type	Pipe Size & End to End (mm)	Live Length (mm)	Corrugations per meter	Corrugations			Rated Pressure @21°C (kg/cm ²)
				A (mm)	B (mm)	C (mm)	
VGWNS	350 X 3626	1320	59	1899	1943	1981	12
VGWNS	400 X 3994	1422	52	2089	2134	2172	12
VGWNS	450 X 4559	1727	49	2200	2429	2537	12
VGWNS	508 X 4928	1727	49	1829	2708	2746	12
VGWNS	610 X 5607	1727	49	1981	2896	2940	12

End to End Tolerance: minus 1% plus 3%. Minimum Burst is four times the Rated Pressure. Safety factor of 4. Sizes 20" and 24" have Double "Ribbon" Braid.

QTY	SIZE	TAG

QTY	SIZE	TAG