



MASON INDUSTRIES, Inc.

Manufacturers of Vibration Control Products
 350 Rabro Drive 2101 W. Crescent Ave., Suite D
 Hauppauge, NY 11788 Anaheim, CA 92801
 631/348-0282 714/535-2727
 FAX 631/348-0279 FAX 714/535-5738
 Info@Mason-Ind.com Info@MasonAnaheim.com
 www.Mason-Ind.com

JOB NAME _____
 CUSTOMER _____
 CUSTOMER P.O. _____
 MASON M.I. _____
 DWG. NO. _____

WFD
 Welded
 Floor Drain

PIPE CONNECTIONS:

- 1 1/2 NPT
- 2 NPT
- 2 1/2 NPT
- 3 NPT
- 4 NPT
- OTHER _____

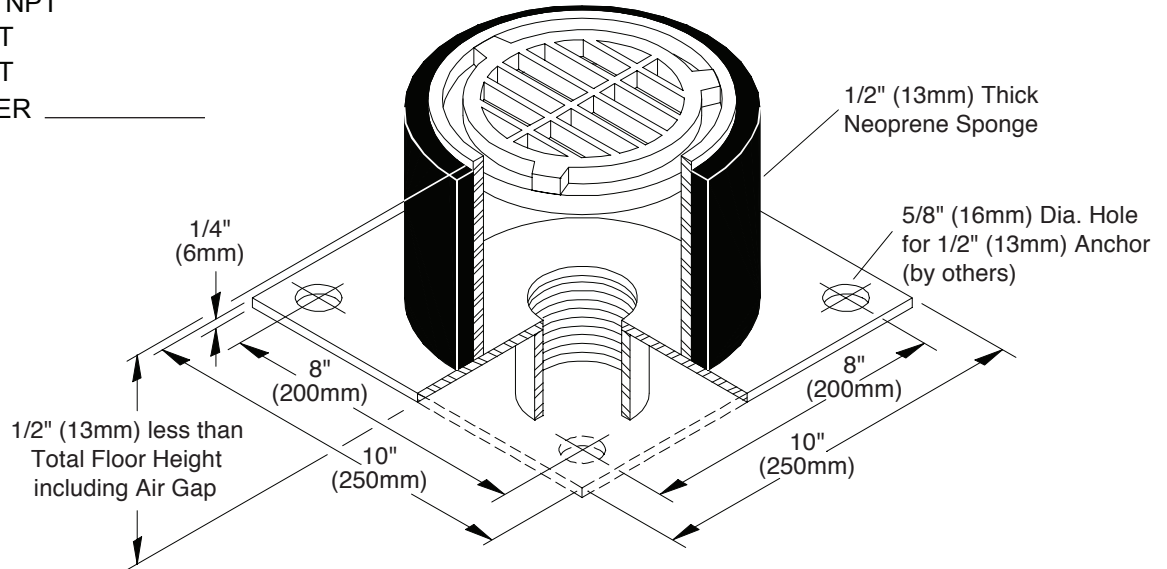

NOTES:

1. Drain must be adequately waterproofed for 2 ft (600mm) around floor drain. The plastic sheet (bond breaker) must be taped to the drain base plate.
2. Caulk around drain after concrete has cured.

Floor Thickness	Air Gap	Total Height	Height Of Drain (1/2" (13mm) less than the total height)	Number of Drains Required