



MASON INDUSTRIES, Inc.

Manufacturers of Vibration Control Products

350 Rabro Drive 2101 W. Crescent Ave., Suite D
 Hauppauge, NY 11788 Anaheim, CA 92801
 631/348-0282 714/535-2727
 FAX 631/348-0279 FAX 714/535-5738
 Info@Mason-Ind.com Info@MasonAnaheim.com
 www.Mason-Ind.com

JOB NAME _____
 CUSTOMER _____
 CUSTOMER P.O. _____
 MASON M.I. _____
 DWG. NO. _____

WHS

2"(50mm) Defl.
 B & B2 Series
 Ceiling Hangers

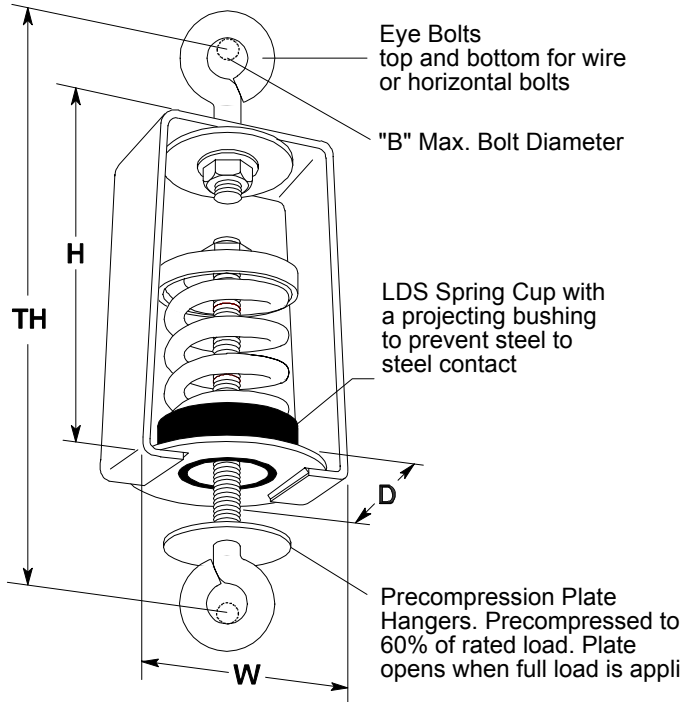

TYPE WHS RATINGS

Size	Rated Capacity		Rated Defl. [†]		Spring Constant ^{††}		Spring Color/Stripe
	(lbs)	(kg)	(in)	(mm)	(lbs/in)	(kg/mm)	
WHS-B-20	20	9	2.40	61	8	0.15	Tan
WHS-B-26	26	12	2.18	55	12	0.22	White/Blue
WHS-B-35	35	16	2.20	56	16	0.29	Purple
WHS-B-50	50	23	2.20	56	24	0.41	White/Red
WHS-B-65	65	30	2.10	53	31	0.57	Brown
WHS-B-85	85	39	2.10	53	40	0.74	White/Blk
WHS-B-115	115	52	2.00	51	57	1.0	Silver
WHS-B-150	150	68	2.00	51	75	1.3	Orange
WHS-B2-210	210	96	2.12	54	99	1.8	Silver
WHS-B2-290	290	132	2.00	51	144	2.6	Blue
WHS-B2-450 [‡]	450	205	2.00	51	224	4.0	Tan
WHS-B2-680 [‡]	680	309	2.00	51	340	6.1	Gray

[†] includes double deflection neoprene element

^{††} applies to spring only.

[‡]Published ratings allow minimum 25% additional travel to solid. For a full 50% specified minimum, use the following ratings:

Size	Capacity		Deflection	
	(lbs)	(kg)	(in)	(mm)
B2-450	410	186	1.83	46.5
B2-680	565	257	1.66	42.2

Hanger Elements have straight line deflection curves.

TH - Total Height between Bolt Centers as installed

TYPE WHS DIMENSIONS (inches)

Size Range	B	D	H	W	TH
WHS-B-20-150	1/2	4	7 1/4	4 3/4	10
WHS-B2-210-680	1/2	4	7 1/4	4 3/4	10

TYPE WHS DIMENSIONS (mm)

Size Range	B	D	H	W	TH
WHS-B-20-150	13	102	184	121	254
WHS-B2-210-680	13	102	184	121	254

CERTIFICATION DATA

MASON LAYOUT DRAWING NO. _____

_____ SPECIFIED DEFLECTION

SIZE	QTY.	TAG