



**MASON INDUSTRIES, Inc.**

**MERCER RUBBER Co.**

350 Rabro Drive, Hauppauge, NY 11788  
 Mason- 631/348-0282 • Info@Mason-Ind.com  
 Mercer- 631/582-1524 • Info@Mercer-Rubber.con.  
 FAX 631/348-0279



JOB NAME \_\_\_\_\_  
 CUSTOMER \_\_\_\_\_  
 CUSTOMER P.O. \_\_\_\_\_  
 MASON M. \_\_\_\_\_  
 DWG No. \_\_\_\_\_

**BJF150**

**BALL JOINT with  
 FIXED and  
 FLOATING  
 FLANGES**

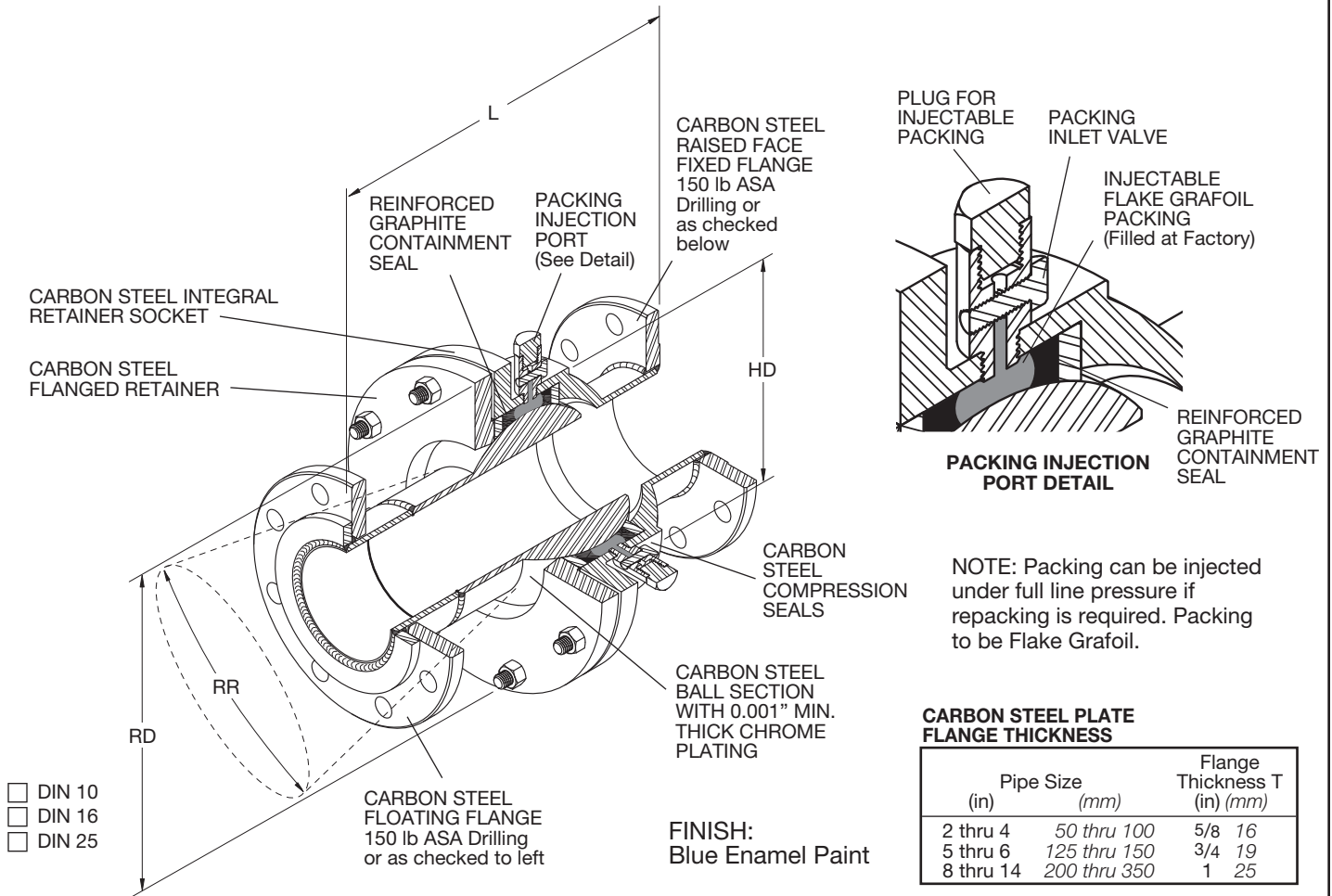

**BJF150 DIMENSIONS AND PRESSURE RATINGS**

Type & Size	Pipe Size (in) (mm)	L Overall Length (in) (mm)	RD Retainer Diameter (in) (mm)	HD Housing Diameter (in) (mm)	RR* Rated Rotation (degrees)	Rated Pressure @480°F @250°C (psi) (kg/cm²)	Number of Ports
BJF150-2	2 50	101/4 260	-	51/4 135	30	250 17	3
BJF150-2 1/2	2 1/2 65	111/8 283	-	6 150	15	250 17	3
BJF150-3	3 80	113/4 298	-	6 1/2 165	15	250 17	3
BJF150-4	4 100	133/4 349	107/8 275	77/8 200	15	250 17	4
BJF150-5	5 125	137/8 352	12 305	9 230	15	250 17	4
BJF150-6	6 150	151/8 384	13 1/4 340	10 1/2 265	15	250 17	5
BJF150-8	8 200	175/8 448	16 405	13 330	15	250 17	6
BJF150-10	10 250	191/4 489	19 3/8 492	16 405	15	250 17	7
BJF150-12	12 300	213/8 543	22 557	18 1/2 470	15	250 17	8
BJF150-14	14 350	221/2 572	23 5/8 600	20 510	15	250 17	9

\*NOTE: All ball joints provide 360° torsional rotation.

QTY	SIZE	TAG

QTY	SIZE	TAG