



MASON INDUSTRIES, Inc.

MERCER RUBBER Co.

350 Rabro Drive, Hauppauge, NY 11788
 Mason- 631/348-0282 • Info@Mason-Ind.com
 Mercer- 631/582-1524 • Info@Mercer-Rubber.con.
 FAX 631/348-0279



JOB NAME _____
 CUSTOMER _____
 CUSTOMER P.O. _____
 MASON M. _____
 DWG No. _____

BJW250

BALL JOINT with WELD ENDS

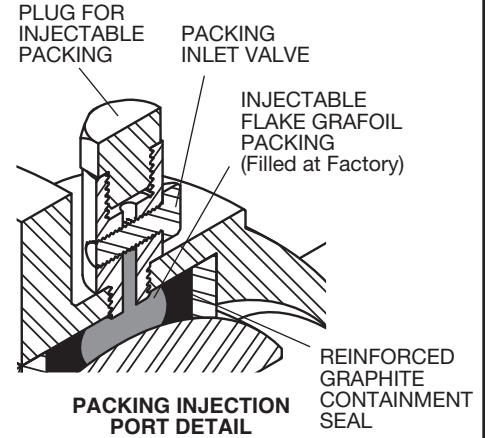
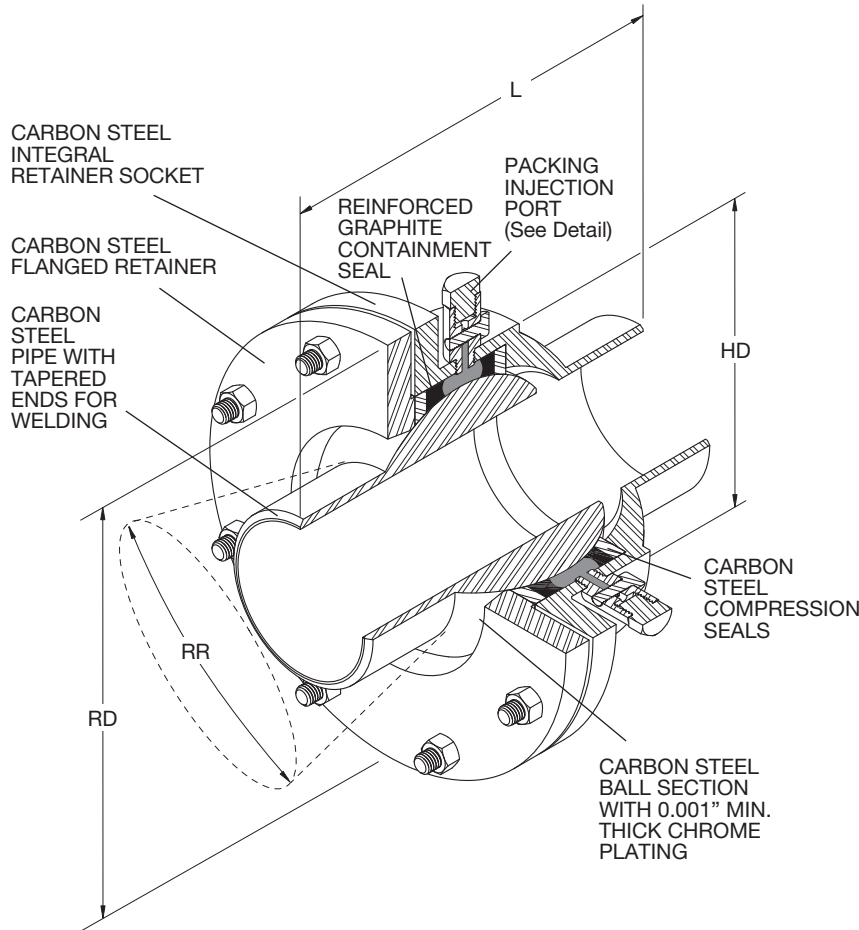

NOTE: Packing can be injected under full line pressure if repacking is required. Packing to be Flake Grafoil.

FINISH:
Blue Enamel Paint

BJW250 DIMENSIONS AND PRESSURE RATINGS

Type & Size	Pipe Size (in) (mm)	L Overall Length (in) (mm)		RD Retainer Diameter (in) (mm)		HD Housing Diameter (in) (mm)		RR* Rated Rotation (degrees)	Rated Pressure @480°F @250°C (psi) (kg/cm ²)		Number of Ports
BJW250-2	2 50	7	180	-	-	5 1/4	135	30	250	17	3
BJW250-2 1/2	2 1/2 65	7 7/8	200	-	-	6	150	15	250	17	3
BJW250-3	3 80	8 1/2	218	-	-	6 1/2	165	15	250	17	3
BJW250-4	4 100	10 1/2	267	10 7/8	275	7 7/8	200	15	250	17	4
BJW250-5	5 125	10 5/8	270	12	305	9	230	15	250	17	4
BJW250-6	6 150	11 7/8	300	13 1/4	340	10 1/2	265	15	250	17	5
BJW250-8	8 200	14 3/8	365	16	405	13	330	15	250	17	6
BJW250-10	10 250	16	405	19 3/8	492	16	405	15	250	17	7
BJW250-12	12 300	18 1/8	460	22	557	18 1/2	470	15	250	17	8
BJW250-14	14 350	19 1/4	490	23 5/8	600	20	510	15	250	17	9

*NOTE: All ball joints provide 360° torsional rotation.

QTY	SIZE	TAG

QTY	SIZE	TAG