



# MASON INDUSTRIES, Inc.

Manufacturers of Vibration Control Products  
 350 Rabro Drive 2101 W. Crescent Ave., Suite D  
 Hauppauge, NY 11788 Anaheim, CA 92801  
 631/348-0282 714/535-2727  
 FAX 631/348-0279 FAX 714/535-5738  
 Info@Mason-Ind.com Info@MasonAnaheim.com  
 www.Mason-Ind.com

JOB NAME \_\_\_\_\_  
 CUSTOMER \_\_\_\_\_  
 CUSTOMER P.O. \_\_\_\_\_  
 MASON M.I. \_\_\_\_\_ DWG. NO. \_\_\_\_\_  
 NO. REQ'D \_\_\_\_\_ TAG NO. \_\_\_\_\_

## BMK/KSL

**Bolted  
 Modular  
 Concrete  
 Base**

MANUF. _____	TYPE _____	SUCTION SIZE _____	MOTOR H.P. _____
SIZE _____ MODEL _____	CLOSE COUPLED _____	_____	FRAME SIZE _____
BASE NUMBER _____	END SUCTION _____	_____	R.P.M. _____
_____	DOUBLE SUCTION _____	_____	_____

WEIGHTS: STEEL BASE _____	BASE w/ CONCRETE _____	PUMP WEIGHT _____
---------------------------	------------------------	-------------------

REF. DWG. NO. _____	FOR SPRING MOUNT DATA, SEE FORM NO. _____	_____ SPECIFIED DEFLECTION
---------------------	---	----------------------------

Typical Base Layout- For actual locations, see plan view below.

NOTE: 3/8" Square Bar is equivalent in area to 1/2" Round Bar

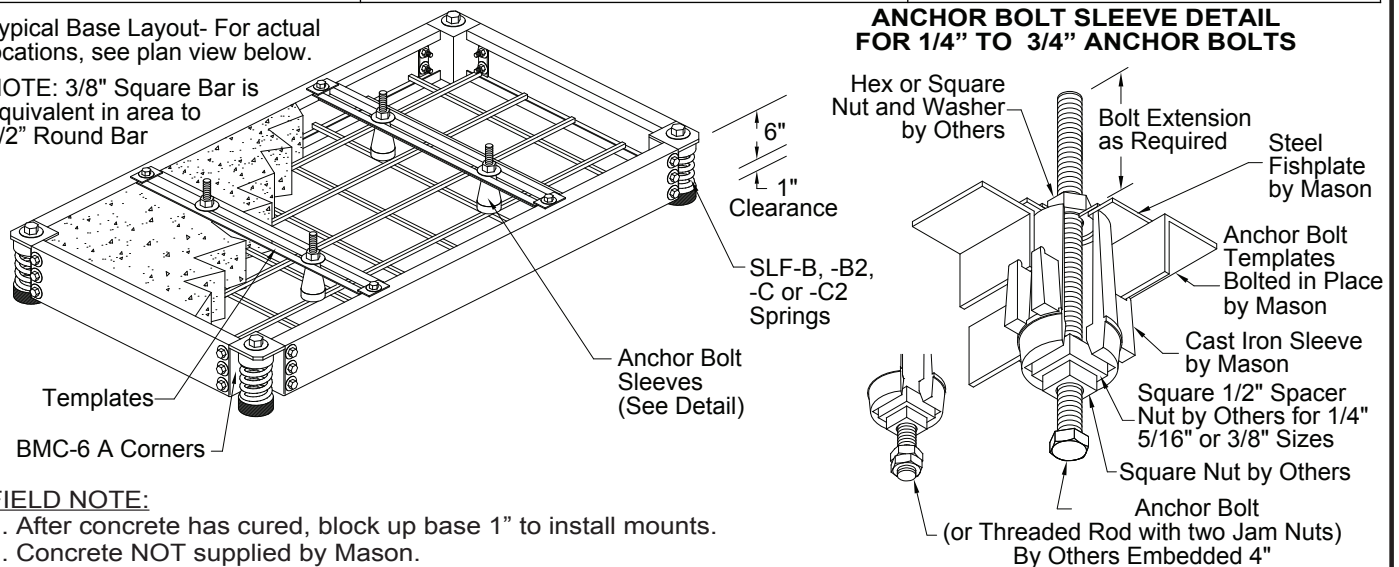

**FIELD NOTE:**

1. After concrete has cured, block up base 1" to install mounts.
2. Concrete NOT supplied by Mason.

**ANCHOR BOLT INSTALLATION INSTRUCTIONS**

1. BMK Bases ordered with Anchor Bolt Templates are furnished with templates already in place.
2. The Mounting Carton contains the necessary number of cast iron sleeves and fishplates shown in position on the base drawing.
3. Install Anchor Bolts in position in locations shown on the drawing before pouring concrete.

