



MASON INDUSTRIES, Inc.

MERCER RUBBER Co.

350 Rabro Drive, Hauppauge, NY 11788
Mason- 631/348-0282 • Info@Mason-Ind.com
Mercer- 631/582-1524 • Info@Mercer-Rubber.com
FAX 631/348-0279



JOB NAME
CUSTOMER
CUSTOMER P.O.
MASON M.
DWG No.

CSAVFL

60Vee SS BRAIDED HOSE with CARBON STEEL FLOATING FLANGES



These assemblies have been "CSA International" approved for use on gas pipelines. "CSA International" is the current certification agency for gas industry products, assuming the authority formerly associated with the American Gas Association (AGA).

Our Certification Report is #230720-1764990. This Certification meets all requirements of ANSI/UL #536 2003 Standards for Flexible Metal Hose.

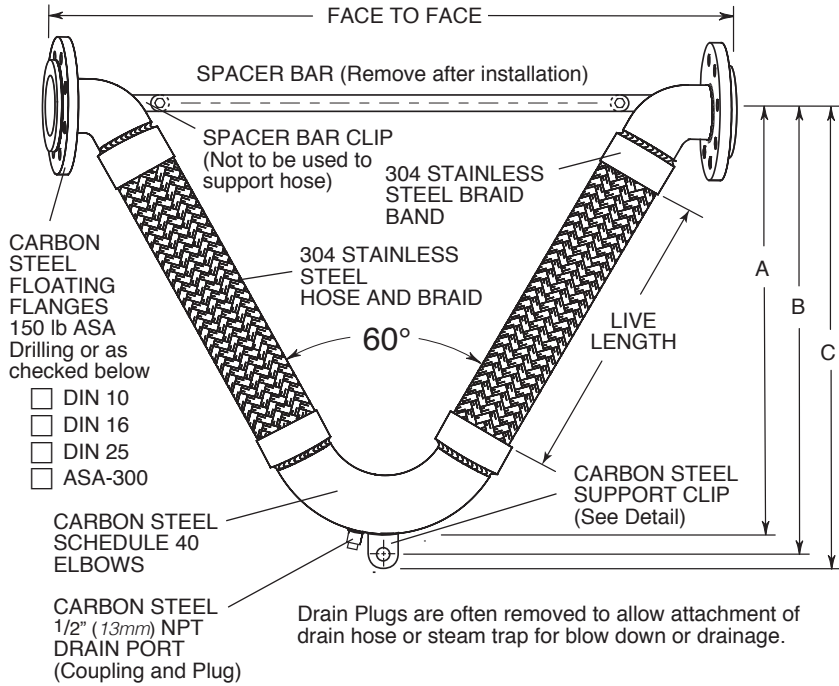
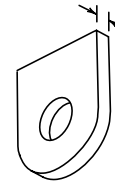

PLATE FLANGE THICKNESS

Table with 3 columns: Pipe Size (in/mm), Flange Thickness (in/mm), and values for 2 thru 4, 50 thru 100, 5/8, 16.

CLIP THICKNESS



SUPPORT CLIP DETAIL

SUPPORT CLIP

Table with 4 columns: Pipe Size (in/mm), SUPPORT CLIP Hole Diameter (in/mm), Thickness (in/mm), and values for various pipe sizes.

OPTIONAL FITTINGS MATERIAL as checked below

Stainless Steel

RATED MOVEMENTS

±4" (100mm) All Directional Seismic Movement
±6" (150mm) Guided Thermal Movement Only

CSAVFL DIMENSIONS AND PRESSURE RATINGS (American Units)

Table with 9 columns: Pipe Size & Face to Face (in), Live Length (in), Corrugations per foot, A (in), B (in), C (in), Rated Pressure @70°F (psi), Min Burst Pressure (psi), Safety Factor.

CSAVFL DIMENSIONS AND PRESSURE RATINGS (Metric Units)

Table with 9 columns: Pipe Size & Face to Face (mm), Live Length (mm), Corrugations per meter, A (mm), B (mm), C (mm), Rated Pressure @70°F (kg/cm²), Min Burst Pressure (kg/cm²), Safety Factor.

Face to Face Tolerance: minus 1% plus 3%.

Table with 3 columns: QTY, SIZE, TAG

Table with 3 columns: QTY, SIZE, TAG