



MASON INDUSTRIES, Inc.

MERCER RUBBER Co.

350 Rabro Drive, Hauppauge, NY 11788
Mason- 631/348-0282 • Info@Mason-Ind.com
Mercer- 631/582-1524 • Info@Mercer-Rubber.com
FAX 631/348-0279



JOB NAME
CUSTOMER
CUSTOMER P.O.
MASON M.
DWG No.

CSAWN

SS BRAIDED HOSE with CARBON STEEL WELD NIPPLES

Full Vacuum Rating- 30" (762mm) Hg

CARBON STEEL SCHEDULE 40 BEVELED WELD NIPPLES or as checked below
[] Stainless Steel

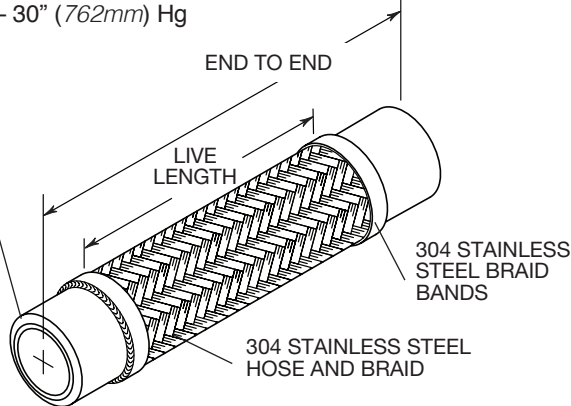

These assemblies have been "CSA International" approved for use on gas pipelines. "CSA International" is the current certification agency for gas industry products, assuming the authority formerly associated with the American Gas Association (AGA).

Our Certification Report is #230720-1764990. This Certification meets all requirements of ANSI/UL #536 2003 Standards for Flexible Metal Hose.

CSAWN DIMENSIONS AND PRESSURE RATINGS (American Units)

Table with 8 columns: Pipe Size, End to End, Live Length, Corrugations per foot, Maximum Permanent Lateral Offset, Rated Pressure @70°F, Min Burst Pressure, Safety Factor. Rows include sizes from 1/2 to 4 inches.

CSAWN DIMENSIONS AND PRESSURE RATINGS (Metric Units)

Table with 8 columns: Pipe Size, End to End, Live Length, Corrugations per meter, Maximum Permanent Lateral Offset, Rated Pressure @21°C, Min Burst Pressure, Safety Factor. Rows include sizes from 15 to 100 mm.

End to End Tolerance: minus 1% plus 3%. Lateral Offset one side of centerline and normal machinery vibration. If intermittent in both directions, reduce by 50%.

Table with 3 columns: QTY, SIZE, TAG

Table with 3 columns: QTY, SIZE, TAG