



MASON INDUSTRIES, Inc.

MERCER RUBBER Co.

350 Rabro Drive, Hauppauge, NY 11788
 Mason- 631/348-0282 • Info@Mason-Ind.com
 Mercer- 631/582-1524 • Info@Mercer-Rubber.com
 FAX 631/348-0279



JOB NAME _____
 CUSTOMER _____
 CUSTOMER P.O. _____
 MASON M. _____
 DWG No. _____

EFL50
 50 psi FULL VACUUM
 SS BELLOWS
 EXPANSION
 JOINT with CARBON
 STEEL FIXED and
 FLOATING FLANGES

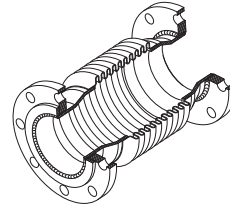
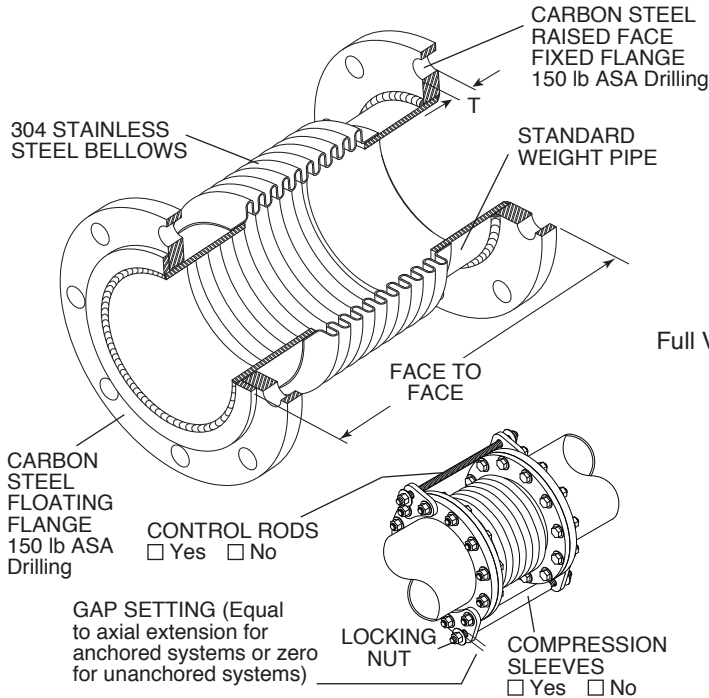

Our 4" designs use 5" stainless bellows between reducers for greater stability.

EFL50 RATED PRESSURES @ ELEVATED TEMPERATURES

Temperature (°F)	Temperature (°C)	Rated Pressure (psi)	Rated Pressure (kg/cm²)
200	93	46	3.2
300	149	43	3.0
400	204	39	2.7
500	260	38	2.7
800	427	37	2.6
1000	538	30	2.1
1500	816	13	0.9

Full Vacuum Rating- 30" (762mm) Hg

GUIDE SPACING - Referencing Pipe Diameter "D"

Guides and Anchors for Joint located near Anchor

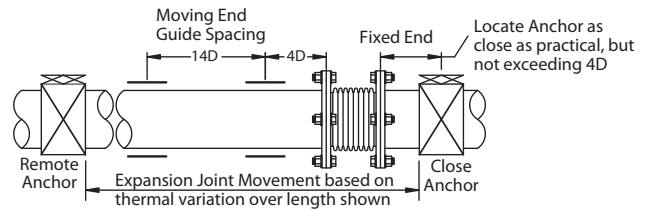

Guides and Anchors for Joint located between Remote Anchors

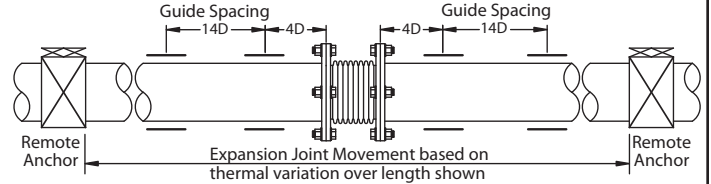

FLANGE BOLTS and NUTS REQUIREMENT

EFL50 Size	Quantity per End	Size & Length
4	16	5/8 x 3 1/4
5 & 6	16	3/4 x 3 1/2
8	16	3/4 x 4
10 & 12	24	7/8 x 4 1/4
14	24	1 x 4 1/2
16	32	1 x 4 1/2

CARBON STEEL PLATE FLANGES

Pipe Size (in)	Pipe Size (mm)	Flange Thickness T (in)	Flange Thickness T (mm)
4	100	5/8	16
5 thru 6	125 thru 150	3/4	19
8 thru 16	200 thru 406	1	25

EFL50 DIMENSIONS AND PRESSURE RATINGS (American & Metric Units) 2" (50mm) COMBINED AXIAL MOVEMENT, 1/4" (6mm) LATERAL DEFLECTION

Type & Size	Pipe Size (in)	Pipe Size (mm)	Face to Face (in)	Face to Face (mm)	Axial Spring Rate (lbs/in)	Axial Spring Rate (kg/cm)	Lateral Spring Rate (lbs/in)	Lateral Spring Rate (kg/cm)	Thrust [®] 50 psi (lbs)	Thrust [®] 3 kg/cm² (kg)	Rated Pressure @70°F (psi)	Rated Pressure @21°C (kg/cm²)	Ship Wt. (lbs)	Ship Wt. (kg)
EFL50-4	4	100	21	533	640	115	850	152	1400	635	50	3	33	15
EFL50-5	5	125	14 1/4	362	640	115	850	152	1400	635	50	3	35	16
EFL50-6	6	150	15 1/4	387	890	159	1400	250	1900	862	50	3	43	20
EFL50-8	8	200	15 1/2	394	1130	202	3700	661	3200	1451	50	3	78	35
EFL50-10	10	250	15 3/4	400	1250	223	6400	1143	4800	2177	50	3	100	45
EFL50-12	12	300	17 3/4	451	1360	243	7790	1391	6600	2994	50	3	140	64
EFL50-14	14	350	18 1/2	470	1410	252	9450	1688	8800	3992	50	3	181	82
EFL50-16	16	400	19	483	1810	323	18160	3243	11300	5126	50	3	226	103

EFL may be used for 2" Expansion or 2" Compression from neutral length or any combined 2" from neutral. i.e. (+ 1 1/2, - 1/2) (+ 1, - 1) (+ 1/4, - 13/4) etc. Total movement should never exceed 2".

Lower Thrust Forces in proportion at lower pressures, i.e. 20 psi Force = 20/50 x published Thrust. Anchors must resist Thrust Force plus Spring Force. Spring Force is determined by multiplying the joint Spring Rate by its Thermal Movement (in/mm).

EFL's installed in piping systems must be anchored on both sides of the joint. EFL's installed in unanchored piping must have control rods.

When using EFL products in copper or brass water or steam systems, dielectric flanges must be used on each end to prevent leakage from galvanic action.

QTY	SIZE	TAG

QTY	SIZE	TAG