



MASON INDUSTRIES, Inc.

MERCER RUBBER Co.

350 Rabro Drive, Hauppauge, NY 11788
Mason- 631/348-0282 • Info@Mason-Ind.com
Mercer- 631/582-1524 • Info@Mercer-Rubber.com
FAX 631/348-0279



JOB NAME
CUSTOMER
CUSTOMER P.O.
MASON M.
DWG No.



SS BRAIDED HOSE with CARBON STEEL FIXED & FLOATING FLANGES

Full Vacuum Rating- 30" (762mm) Hg

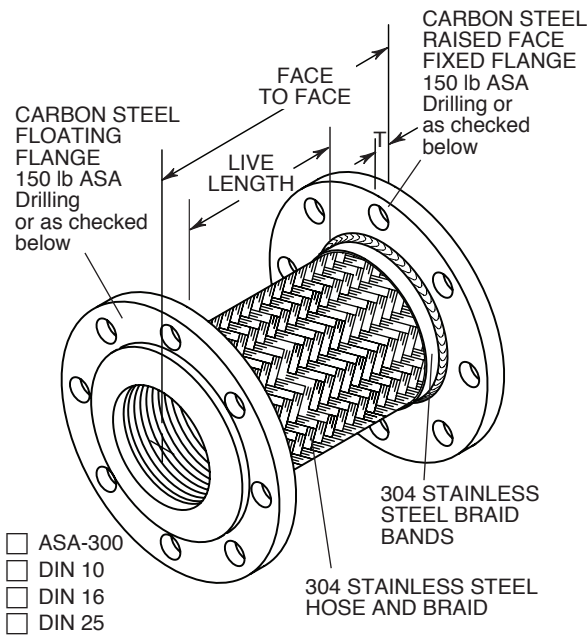

CARBON STEEL PLATE FLANGE THICKNESS

Table with 3 columns: Pipe Size (in/mm), Flange Thickness T (in/mm), and values for different pipe sizes.

RATED PRESSURES @ ELEVATED TEMPERATURES (psi) (kg/cm²)

Table with 4 columns: Hose Size (in/mm), 250°F (121°C), 350°F (176°C), and 450°F (232°C). Includes safety factors.

Industry Standard Pump Connectors

Short lengths conserve space but allow minimum motion and attenuation. Offset Ratings are industry standard.

SATURATED STEAM RECOMMENDED PRESSURE LIMITS

Table with 3 columns: Size (in/mm), Max Gauge (psi/kg/cm²), and Temp Reference (F/°C).

Our steam service ratings are very low in the interest of safety although our 70°F (21°C) pressure ratings are as high or higher than our competitors.

Consult factory with full location description as well as service conditions for higher pressure or temperature applications.

304 SS can be used up to 850°F (454°C) in applications such as engine exhaust.

When using FFL products in copper or brass water or steam systems, dielectric flanges must be used on each end to prevent leakage from galvanic action.

FFL DIMENSIONS AND PRESSURE RATINGS (American Units)

Table with 6 columns: Type, Pipe Size & Face to Face (in), Live Length (in), Corrugations per foot, Maximum Permanent Lateral Offset (in), and Rated Pressure @70°F (psi).

FFL DIMENSIONS AND PRESSURE RATINGS (Metric Units)

Table with 6 columns: Type, Pipe Size & Face to Face (mm), Live Length (mm), Corrugations per meter, Maximum Permanent Lateral Offset (mm), and Rated Pressure @21°C (kg/cm²).

Face to Face Tolerance: minus 1% plus 3%. Minimum Burst is four times the Rated Pressure. Safety factor of 4. Lateral Offset one side of centerline and normal machinery vibration. If intermittent in both directions, reduce by 50%. Sizes 12" - 16" (300-400mm) have double braid.

Inventory table with columns: QTY, SIZE, TAG

Inventory table with columns: QTY, SIZE, TAG



MASON INDUSTRIES, Inc.

MERCER RUBBER Co.

350 Rabro Drive, Hauppauge, NY 11788
 Mason- 631/348-0282 • Info@Mason-Ind.com
 Mercer- 631/582-1524 • Info@Mercer-Rubber.com
 FAX 631/348-0279



JOB NAME _____
 CUSTOMER _____
 CUSTOMER P.O. _____
 MASON M. _____
 DWG No. _____



SS BRAIDED
 HOSE with
 CARBON STEEL
 FIXED & FLOATING
 FLANGES

CARBON STEEL
 FLOATING FLANGE
 150 lb ASA Drilling
 or as checked below

FACE
 TO FACE

LIVE
 LENGTH

CARBON STEEL
 RAISED FACE FIXED
 FLANGE 150 lb ASA
 Drilling or as checked

304 STAINLESS STEEL,
 BRAID BANDS, HOSE
 AND BRAID

- DIN 10
- DIN 16
- DIN 25
- ASA-300

Full Vacuum Rating- 30" (762mm) Hg

RATED PRESSURES @
 ELEVATED TEMPERATURES (psi) (kg/cm²)

Hose Size (in) (mm)	250°F 121°C Factor 0.92	350°F 176°C Factor 0.86	450°F 232°C Factor 0.81
1 1/2 40	400 28	370 26	350 24
2 50	330 23	310 21	290 20
2 1/2 65	270 19	250 17	235 16
3 80	260 18	240 16	230 16
4 100	210 15	200 14	190 13
5 125	190 13	180 12	170 11
6 150	190 13	180 12	170 11
8 200	190 13	180 12	170 11
10 250	160 11	150 10	140 9
12 300	160 11	150 10	140 9
14 350	160 11	150 10	140 9
16 400	160 11	150 10	140 9

SATURATED STEAM
 RECOMMENDED PRESSURE LIMITS

Size (in) (mm)	Max Gauge (psi) (kg/cm ²)	Temp Reference (F) (°C)
1 1/2 40	150 11	362 183
2 50	150 11	362 183
2 1/2 65	125 9	355 179
3 80	125 9	355 179
4 100	125 9	355 179
5 125	100 7	337 169
6 150	100 7	337 169
8 200	75 5	320 160
10 250	60 4	307 153
12 300	60 4	307 153
14 350	60 4	307 153
16 400	60 4	307 153

FFL DIMENSIONS AND PRESSURE RATINGS (American Units)

Type	Pipe Size & Face to Face (in)	Live Length (in)	Corrugations per foot	Maximum Permanent Lateral Offset (in)	Rated Pressure @70°F (psi)
FFL	1 1/2 X 12	93/4	63	1 1/4	450
FFL	1 1/2 X 18	153/4	63	3 1/2	450
FFL	1 1/2 X 24	213/4	63	6 1/2	450
FFL	2 X 12	93/4	58	1 1/8	360
FFL	2 X 18	153/4	58	2 1/2	360
FFL	2 X 24	213/4	58	5	360
FFL	2 1/2 X 12	9	48	1	290
FFL	2 1/2 X 18	15	48	2 1/4	290
FFL	2 1/2 X 24	21	48	4 3/4	290
FFL	3 X 12	93/4	46	7/8	280
FFL	3 X 18	153/4	46	2	280
FFL	3 X 24	213/4	46	4	280
FFL	3 X 36	333/4	46	8	280
FFL	4 X 12	93/4	32	3/4	225
FFL	4 X 18	153/4	32	1 1/2	225
FFL	4 X 24	213/4	32	3 1/2	225
FFL	4 X 36	333/4	32	7	225
FFL	5 X 18	143/4	29	1 1/4	200
FFL	5 X 24	203/4	29	2 1/4	200
FFL	5 X 36	323/4	29	5 1/2	200
FFL	6 X 18	143/4	25	1	200
FFL	6 X 24	203/4	25	2	200
FFL	6 X 36	323/4	25	5	200
FFL	8 X 18	141/2	23	7/8	200
FFL	8 X 24	201/2	23	1 1/2	200
FFL	8 X 36	321/2	23	4	200
FFL	10 X 18	141/2	21	3/4	170
FFL	10 X 24	201/2	21	1 1/4	170
FFL	10 X 36	321/2	21	3	170
FFL	12 X 24	201/2	20	1	170
FFL	12 X 36	321/2	20	2 1/2	170
FFL	14 X 36	321/2	18	1 1/4	170
FFL	16 X 36	321/2	16	1	170

FFL DIMENSIONS AND PRESSURE RATINGS (Metric Units)

Type	Pipe Size & Face to Face (mm)	Live Length (mm)	Corrugations per meter	Maximum Permanent Lateral Offset (mm)	Rated Pressure @21°C (kg/cm ²)
FFL	40 X 305	248	207	32	31
FFL	40 X 457	400	207	89	31
FFL	40 X 610	552	207	165	31
FFL	50 X 305	248	190	29	25
FFL	50 X 457	400	190	64	25
FFL	50 X 610	552	190	127	25
FFL	65 X 305	248	157	25	20
FFL	65 X 457	400	157	57	20
FFL	65 X 610	552	157	121	20
FFL	80 X 305	248	151	22	19
FFL	80 X 457	400	151	51	19
FFL	80 X 610	552	151	102	19
FFL	80 X 914	857	151	203	19
FFL	100 X 305	248	105	19	15
FFL	100 X 457	400	105	38	15
FFL	100 X 610	552	105	89	15
FFL	100 X 914	857	105	178	15
FFL	125 X 457	375	95	32	14
FFL	125 X 610	527	95	57	14
FFL	125 X 914	832	95	140	14
FFL	150 X 457	375	82	25	14
FFL	150 X 610	527	82	51	14
FFL	150 X 914	832	82	127	14
FFL	200 X 457	368	75	22	14
FFL	200 X 610	521	75	32	14
FFL	200 X 914	826	75	102	14
FFL	250 X 457	368	69	19	11
FFL	250 X 610	521	69	32	11
FFL	250 X 914	826	69	76	11
FFL	300 X 610	521	66	25	11
FFL	300 X 914	826	66	64	11
FFL	350 X 914	826	59	32	11
FFL	400 X 914	826	52	25	11

Our steam service ratings are very low in the interest of safety although our 70°F (21°C) pressure ratings are as high or higher than our competitors. All locations where failure could lead to personal injury or suffocation must be avoided. In dangerous locations we suggest housed expansion joints, solid loops, ball joints, packed devices etc. rather than thin walled flexible products regardless of manufacturer.

Consult factory with full location description as well as service conditions for higher pressure or temperature applications.

304 SS can be used up to 850°F (454°C) in applications such as engine exhaust.

When using FFL products in copper or brass water or steam systems, dielectric flanges must be used on each end to prevent leakage from galvanic action.

CARBON STEEL PLATE FLANGE THICKNESS

Pipe Size (in)	Flange Thickness T (in) (mm)
1 1/2 thru 4	5/8 16
5 thru 6	3/4 19
8 thru 16	1 25

Face to Face Tolerance: minus 1% plus 3%. Minimum Burst is four times the Rated Pressure. Safety factor of 4. Lateral Offset one side of centerline and normal machinery vibration. If intermittent in both directions, reduce by 50%. Sizes 12" - 16" (300-400mm) have double braid.

QTY	SIZE	TAG

QTY	SIZE	TAG