



MASON INDUSTRIES, Inc.

MERCER RUBBER Co.

350 Rabro Drive, Hauppauge, NY 11788
 Mason- 631/348-0282 • Info@Mason-Ind.com
 Mercer- 631/582-1524 • Info@Mercer-Rubber.com
 FAX 631/348-0279



JOB NAME _____
 CUSTOMER _____
 CUSTOMER P.O. _____
 MASON M. _____
 DWG No. _____

GWN

**SS BRAIDED HOSE
 with CARBON STEEL
 GROOVED
 WELD NIPPLES**

Full Vacuum Rating- 30" (762mm) Hg

CARBON STEEL
 SCHEDULE 40
 NIPPLES grooved
 for couplings
 and beveled for
 welding alternate

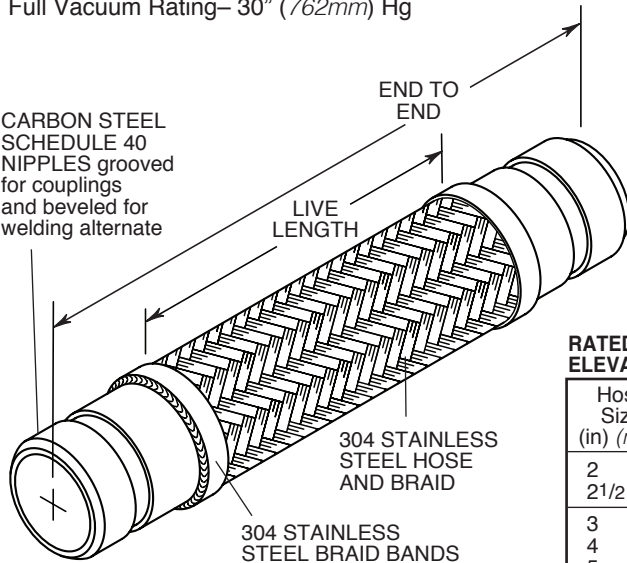

Our steam service ratings are very low in the interest of safety although our 70°F (21°C) pressure ratings are as high or higher than our competitors. All locations where failure could lead to personal injury or suffocation must be avoided. In dangerous locations we suggest housed expansion joints, solid loops, ball joints, packed devices etc. rather than thin walled flexible products regardless of manufacturer.

Consult factory with full location description as well as service conditions for higher pressure or temperature applications.

304 SS can be used up to 850°F (454°C) in applications such as engine exhaust.

When using GWN products in copper or brass water or steam systems, dielectric couplings must be used on each end to prevent leakage from galvanic action.

**RATED PRESSURES @
 ELEVATED TEMPERATURES (psi) (kg/cm²)**

Hose Size (in) (mm)	250°F 121°C	350°F 176°C	450°F 232°C
	Factor 0.92	Factor 0.86	Factor 0.81
2 50	330 23	310 21	290 20
2 1/2 65	270 19	250 17	235 16
3 80	260 18	240 16	230 16
4 100	210 15	200 14	190 13
5 125	190 13	180 12	170 11
6 150	190 13	180 12	170 11
8 200	190 13	180 12	170 11
10 250	160 11	150 10	140 9
12 300	160 11	150 10	140 9

**SATURATED STEAM RECOMMENDED
 PRESSURE LIMITS**

Size (in) (mm)	Max Gauge (psi) (kg/cm²)	Temp Reference (°F) (°C)
2 50	150 11	362 183
2 1/2 65	125 9	355 179
3 80	125 9	355 179
4 100	125 9	355 179
5 125	100 7	337 169
6 150	100 7	337 169
8 200	75 5	320 160
10 250	60 4	307 153
12 300	60 4	307 153

GWN DIMENSIONS AND PRESSURE RATINGS (American Units)

Type	Pipe Size & End to End (in)	Live Length (in)	Corrugations per foot	Maximum Permanent Lateral Offset (in)	Rated Pressure @70°F (psi)
GWN	2 X 14	83/4	58	1	360
GWN	2 X 24	183/4	58	33/4	360
GWN	2 X 36	303/4	58	8	360
GWN	2 1/2 X 14	8	48	7/8	290
GWN	2 1/2 X 24	18	48	3	290
GWN	2 1/2 X 36	30	48	7	290
GWN	3 X 14	8	46	3/4	280
GWN	3 X 36	30	46	6	280
GWN	4 X 18	10	32	3/4	225
GWN	4 X 36	28	32	5	225
GWN	5 X 20	12	29	3/4	200
GWN	5 X 36	28	29	4	200
GWN	6 X 22	14	25	3/4	200
GWN	6 X 36	28	25	3 1/2	200
GWN	8 X 24	16	23	1/4	200
GWN	8 X 36	28	23	3	200
GWN	10 X 28	18	21	3/4	170
GWN	10 X 36	26	21	2	170
GWN	12 X 30	20	20	3/4	170
GWN	12 X 36	26	20	13/4	170

GWN DIMENSIONS AND PRESSURE RATINGS (Metric Units)

Type	Pipe Size & End to End (mm)	Live Length (mm)	Corrugations per meter	Maximum Permanent Lateral Offset (mm)	Rated Pressure @21°C (kg/cm²)
GWN	50 X 356	222	190	25	25
GWN	50 X 610	476	190	95	25
GWN	50 X 914	781	190	203	25
GWN	65 X 356	203	157	22	20
GWN	65 X 610	457	157	76	20
GWN	65 X 914	762	157	178	20
GWN	80 X 356	203	151	19	19
GWN	80 X 900	762	151	152	19
GWN	100 X 457	254	105	19	15
GWN	100 X 914	711	105	127	15
GWN	125 X 508	305	95	19	14
GWN	125 X 914	711	95	102	14
GWN	150 X 559	356	82	19	14
GWN	150 X 914	711	82	89	14
GWN	200 X 610	406	75	19	14
GWN	200 X 914	711	75	76	14
GWN	250 X 711	457	69	19	12
GWN	250 X 914	660	69	51	12
GWN	300 X 762	508	66	19	11
GWN	300 X 914	660	66	44	11

End to End Tolerance: minus 1% plus 3%. Minimum Burst is four times the Rated Pressure. Safety factor of 4.
 Lateral Offset one side of centerline and normal machinery vibration. If intermittent in both directions, reduce by 50%.
 Size 12" (300mm) has double braid.

QTY	SIZE	TAG

QTY	SIZE	TAG