



MASON INDUSTRIES, Inc.

MERCER RUBBER Co.

350 Rabro Drive, Hauppauge, NY 11788
 Mason- 631/348-0282 • Info@Mason-Ind.com
 Mercer- 631/582-1524 • Info@Mercer-Rubber.com
 FAX 631/348-0279



JOB NAME _____
 CUSTOMER _____
 CUSTOMER P.O. _____
 MASON M. _____
 DWG No. _____

RFB

**RESTRAINED
 FLANGED
 BELLOWS**

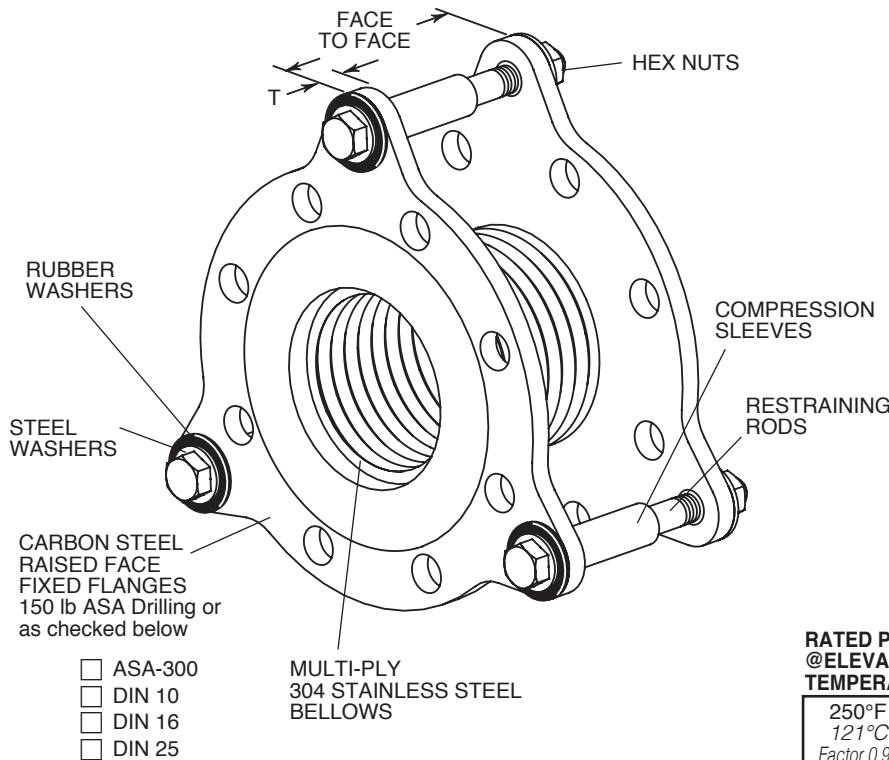

All Restrained Flanged Bellows are designed for 1" (25mm) Compression, 3/8" (9mm) Elongation and 1/8" (3mm) Transverse movement. If piping is not anchored, the pressure will open the joints 3/8" (9mm). When proper anchors are installed, movements will take place as required.

**CARBON STEEL PLATE
 FLANGE THICKNESS**

Pipe Size (in)	Flange Thickness T (in) (mm)
2 thru 4	5/8 16
5 thru 6	3/4 19
8 thru 16	1 25

RATED PRESSURES @ELEVATED TEMPERATURES (psi) (kg/cm²)

250°F 121°C	350°F 176°C	450°F 232°C
Factor 0.92	Factor 0.86	Factor 0.81
210 15	200 14	190 13

SATURATED STEAM RECOMMENDED PRESSURE LIMITS

Max Gauge (psi) (kg/cm ²)	Temp Reference (°F) (°C)
125 9	355 179

RFB DIMENSIONS AND PRESSURE RATINGS (American Units)

Type	Pipe Size & Face to Face (in)	Corrugations per foot	Rated Pressure @70°F (psi)
RFB	2 X 6	24	225
RFB	2 1/2 X 6	24	225
RFB	3 X 6	24	225
RFB	4 X 6	24	225
RFB	5 X 6	24	225
RFB	6 X 6	24	225
RFB	8 X 6	24	225
RFB	10 X 8	16	225
RFB	12 X 8	16	225
RFB	14 X 8	16	225
RFB	16 X 8	16	225

RFB DIMENSIONS AND PRESSURE RATINGS (Metric Units)

Type	Pipe Size & Face to Face (mm)	Corrugations per meter	Rated Pressure @21°C (kg/cm ²)
RFB	50 X 152	79	15
RFB	65 X 152	79	15
RFB	80 X 152	79	15
RFB	100 X 152	79	15
RFB	125 X 152	79	15
RFB	150 X 152	79	15
RFB	200 X 152	79	15
RFB	250 X 203	52	15
RFB	300 X 203	52	15
RFB	350 X 203	52	15
RFB	400 X 203	52	15

Full Vacuum Rating- 30" (762mm) Hg

Our steam service ratings are very low in the interest of safety although our 70°F (21°C) pressure ratings are as high or higher then our competitors. All locations where failure could lead to personal injury or suffocation must be avoided. In dangerous locations we suggest housed expansion joints, solid loops, ball joints, packed devices etc. rather than thin walled flexible products regardless of manufacturer.

Consult factory with full location description as well as service conditions for higher pressure or temperature applications.

Face to Face Tolerance: minus 1% plus 3%. Minimum Burst is four times the Rated Pressure. Safety factor of 4.

QTY	SIZE	TAG

QTY	SIZE	TAG